

INSTALLER: THESE INSTRUCTIONS MUST BE CONVEYED TO AND REMAIN WITH THE HOMEOWNER.



INSTALLATION AND OPERATION INSTRUCTIONS

CERTIFIED UNDER CANADIAN AND AMERICAN NATIONAL STANDARDS: CSA 2.33, ANSI Z21.88 FOR VENTED GAS FIREPLACE HEATERS.

If the information in these instructions is not followed exactly, a fire or explosion may result causing property damage, personal injury or death.

Park Avenue™

GD82NT
NATURAL GAS

GD82PT
PROPANE

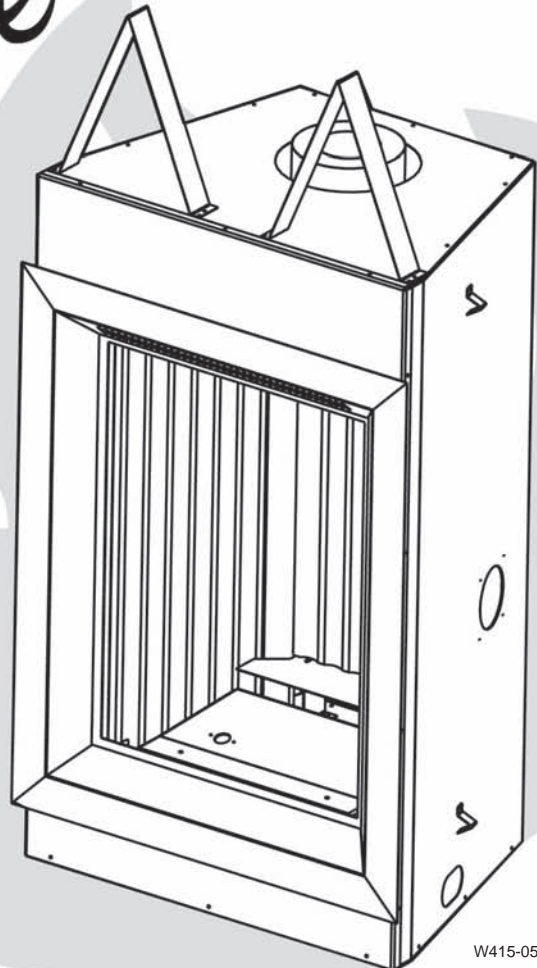

W415-0536 / C / 09.06.06

**Wolf Steel Ltd., 24 Napoleon Rd., Barrie, ON L4M 4Y8 Canada • (705)721-1212 • fax(705)722-6031
www.napoleonfireplaces.com • ask@napoleon.on.ca**

WARNINGS & SAFETY PRECAUTIONS



Do not store gasoline or other flammable vapours and liquids in the vicinity of this or any other appliance.



Installation and service must be performed by a qualified installer, service agency or the gas supplier. Follow the installation directions.

WHAT TO DO IF YOU SMELL GAS



Do not try to light any appliance.



Do not use any phone in your building. Immediately call your gas supplier from a neighbor's phone. Follow the gas supplier's instructions.



Do not touch any electrical switch.



If you cannot reach your gas supplier, call the fire department.



If this fireplace is not properly installed, a house fire may result.

TABLE of CONTENTS

PG2-6	INTRODUCTION Warnings and Safety Precautions Warranty Dimensions General Instructions General Information Care of Glass & Plated Parts	18	BLOWER REPLACEMENT Night Light Replacement
6-10	VENTING Vent lengths Venting Specifications Air Terminal Locations	19	DECORATIVE BRICK PANEL INSTALLATION
11-16	INSTALLATION/FRAMING Wall & Ceiling Protection Using Flexible Vent Components Fireplace Vent Connection Using Rigid Vent Components Gas Installation Restricting Vertical Vents Framing Clearance to Combustibles Mantle Clearances and Enclosures	20	AFK / WI FACE KIT INSTALLATION
16	ELECTRICAL CONNECTION Hard Wiring Connections Schematic	21	REMOTE AND VALVE ACCESS Burner Assembly Removal
17	FINISHING Door Removal Log Shipping Bracket Log Placement Glowing Embers	22-27	OPERATION / MAINTENANCE Fireplace Operation Hand Held Remote Operation Operating Instructions
		27	ADJUSTMENTS Pilot Burner Adjustment Venturi Adjustment
		28-29	REPLACEMENTS Ordering Replacement Parts Replacement Parts Terminal Kits Vent Kits Accessories
		20-31	TROUBLE SHOOTING GUIDE

PLEASE RETAIN THIS MANUAL FOR FUTURE REFERENCE

WARNING

- Do not burn wood or other materials in this fireplace.
- Adults and especially children should be alerted to the hazards of high surface temperatures and should stay away to avoid burns or clothing ignition. Keep young children and animals away when the fireplace is hot.
- Due to high temperatures, the fireplace should be located out of traffic and away from furniture and draperies.
- Clothing or other flammable material should not be placed on or near the fireplace.
- Any safety screen or guard removed for servicing must be replaced prior to operating the fireplace.
- It is imperative that the control compartments, burners and circulating blower and its passageway in the fireplace and venting system are kept clean. The fireplace and its venting system should be inspected before use and at least annually by a qualified service person. More frequent cleaning may be required due to excessive lint from carpeting, bedding material, etc. The fireplace area must be kept clear and free from combustible materials, gasoline and other flammable vapours and liquids.
- Under no circumstances should this fireplace be modified.
- This fireplace must not be connected to a chimney flue pipe serving a separate solid fuel burning appliance.
- Do not use this fireplace if any part has been under water. Immediately call a qualified service technician to inspect the fireplace and to replace any part of the control system and any gas control which has been under water.
- Do not operate the fireplace with the glass door removed, cracked or broken. Replacement of the glass should be done by a licensed or qualified service person.
- Do not strike or slam shut the fireplace glass door.
- This fireplace uses and requires a fast acting thermocouple. Replace only with a fast acting thermocouple supplied by Wolf Steel Ltd.

NAPOLEON products are manufactured under the strict Standard of the world recognized ISO 9001 : 2000 Quality Assurance Certificate.

NAPOLEON products are designed with superior components and materials, assembled by trained craftsmen who take great pride in their work. The burner and valve assembly are leak and test-fired at a quality test station. The complete fireplace is thoroughly inspected by a qualified technician before packaging to ensure that you, the customer, receives the quality product that you expect from NAPOLEON.

NAPOLEON GAS FIREPLACE PRESIDENT'S LIFETIME LIMITED WARRANTY

The following materials and workmanship in your new napoleon gas fireplace are warranted against defects for as long as you own the fireplace. This covers: combustion chamber, heat exchanger, stainless steel burner, PHAZER™ logs and embers, ceramic glass (thermal breakage only), gold plated parts against tarnishing, porcelainized enamelled components and aluminum extrusion trims.

Electrical (110V and millivolt) components and wearable parts such as the blower, gas valve, thermal switch, switches, wiring, remote control, ignitor, gasketing, and pilot assembly are covered and NAPOLEON will provide replacement parts free of charge during the first year of the limited warranty. Light bulbs are not covered by this warranty.

Labour related to warranty repair is covered free of charge during the first year. Repair work, however, requires the prior approval of an authorized company official. Labour costs to the account of NAPOLEON are based on a predetermined rate schedule and any repair work must be done through an authorized NAPOLEON dealer.

CONDITIONS AND LIMITATIONS

NAPOLEON warrants its products against manufacturing defects to the original purchaser only -- i.e., the individual or legal entity (registered customer) whose name appears on the warranty registration card filed with NAPOLEON -- provided that the purchase was made through an authorized NAPOLEON dealer and is subject to the following conditions and limitations:

This factory warranty is nontransferable and may not be extended whatsoever by any of our representatives.

The gas fireplace must be installed by a licenced, authorized service technician or contractor. Installation must be done in accordance with the installation instructions included with the product and all local and national building and fire codes.

This limited warranty does not cover damages caused by misuse, lack of maintenance, accident, alterations, abuse or neglect and parts installed from other manufacturers will nullify this warranty.

This limited warranty further does not cover any scratches, dents, corrosion or discolouring caused by excessive heat, abrasive and chemical cleaners nor chipping on porcelain enamel parts, mechanical breakage of PHAZER™ logs and embers, nor any venting components used in the installation of the fireplace.

NAPOLEON warrants its stainless steel burners against defects in workmanship and material for life, subject to the following conditions: During the first 10 years NAPOLEON will replace or repair the defective parts at our option free of charge. From 10 years to life, NAPOLEON will provide replacement burners at 50% of the current retail price.

In the first year only, this warranty extends to the repair or replacement of warranted parts which are defective in material or workmanship provided that the product has been operated in accordance with the operation instructions and under normal conditions.

After the first year, with respect to this President's Limited Lifetime Warranty, NAPOLEON may, at its discretion, fully discharge all obligations with respect to this warranty by refunding to the original warranted purchaser the wholesale price of any warranted but defective part(s).

After the first year, NAPOLEON will not be responsible for installation, labour or any other costs or expenses related to the reinstallation of a warranted part, and such expenses are not covered by this warranty.

Notwithstanding any provisions contained in this President's Limited Lifetime Warranty, NAPOLEON'S responsibility under this warranty is defined as above and it shall not in any event extend to any incidental, consequential or indirect damages.

This warranty defines the obligations and liability of NAPOLEON with respect to the NAPOLEON gas fireplace and any other warranties expressed or implied with respect to this product, its components or accessories are excluded.

NAPOLEON neither assumes, nor authorizes any third party to assume, on its behalf, any other liabilities with respect to the sale of this product. NAPOLEON will not be responsible for: over-firing, downdrafts, spillage caused by environmental conditions such as rooftops, buildings, nearby trees, hills, mountains, inadequate vents or ventilation, excessive venting configurations, insufficient makeup air, or negative air pressures which may or may not be caused by mechanical systems such as exhaust fans, furnaces, clothes dryers, etc.

Any damages to fireplace, combustion chamber, heat exchanger, brass trim or other component due to water, weather damage, long periods of dampness, condensation, damaging chemicals or cleaners will not be the responsibility of NAPOLEON.

The bill of sale or copy will be required together with a serial number and a model number when making any warranty claims from your authorized dealer. The warranty registration card must be returned within fourteen days to register the warranty.

NAPOLEON reserves the right to have its representative inspect any product or part thereof prior to honouring any warranty claim.

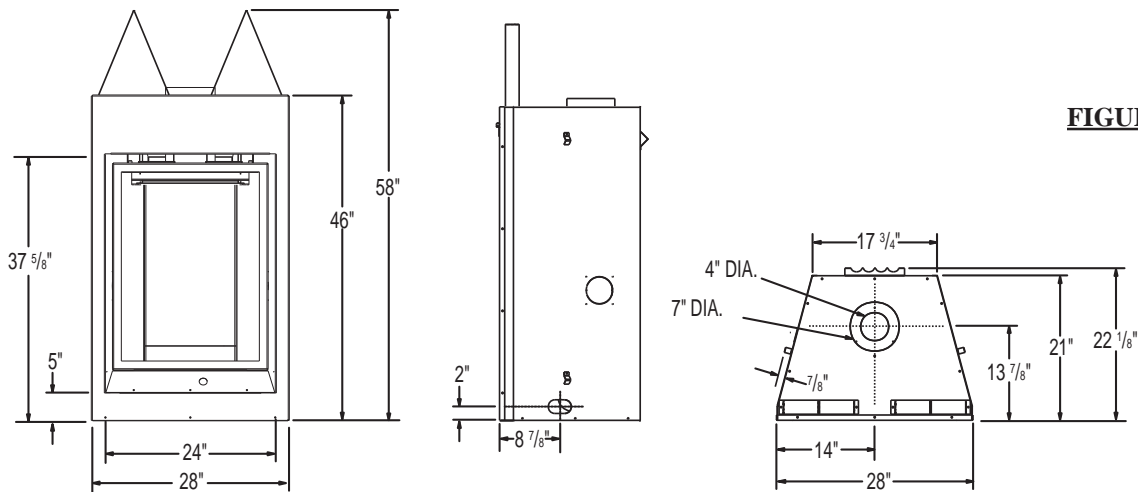

FIGURE 1

GENERAL INSTRUCTIONS

THIS GAS FIREPLACE SHOULD BE INSTALLED AND SERVICED BY A QUALIFIED INSTALLER to conform with local codes. Installation practices vary from region to region and it is important to know the specifics that apply to your area, for example: in Massachusetts State:

- The fireplace damper must be removed or welded in the open position prior to installation of a fireplace insert or gas log.
- A carbon monoxide detector is required in all rooms containing gas fired appliances.
- The appliance off valve must be a "T" handle gas cock.
- The flexible connector must not be longer than 36 inches.
- The appliance is not approved for installation in a bedroom or bathroom unless the unit is a direct vent sealed combustion product.
- **WARNING:** This product must be installed by a licensed plumber or gas fitter when installed within the commonwealth of Massachusetts.

In absence of local codes, install to the current CAN/CGA-B149 Installation Code in Canada or to the National Fuel Gas Code, ANSI Z223.1, and NFPA 54 in the United States. Suitable for mobile home installation if installed in accordance with the current standard CAN/CSA Z240MH Series, for gas equipped mobile homes, in Canada or ANSI Z223.1 and NFPA 54 in the United States.

The fireplace and its individual shutoff valve must be disconnected from the gas supply piping system during any pressure testing of that system at test pressures in excess of 1/2 psig (3.5 kPa). The fireplace must be isolated from the gas supply piping system by closing its individual manual shutoff valve during any pressure testing of the gas supply piping system at test pressures equal to or less than 1/2 psig (3.5 kPa).

When the fireplace is installed directly on carpeting, vinyl tile or other combustible material other than wood flooring, the fireplace shall be installed on a metal or wood panel extending the full width and depth.

The optional heat circulating blower is supplied with a cord. If installed, the junction box must be electrically connected and grounded in accordance with local codes. In the absence of local codes, use the current CSA C22.1 CANADIAN ELECTRICAL CODE in Canada or the ANSI/NFPA 70 NATIONAL ELECTRICAL CODE in the United States.

Purge all gas lines with the glass door of the fireplace open. Assure that a continuous gas flow is at the burner before closing the door.

Under extreme vent configurations, allow several minutes (5-15) for the flame to stabilize after ignition.

Provide adequate ventilation and combustion air.

Provide adequate accessibility clearance for servicing and operating the fireplace. Never obstruct the front opening of the fireplace.

Objects placed in front of the fireplace must be kept a minimum of 48" from the front face of the unit.

Minimum clearance to combustible construction **from fireplace and vent surfaces:**

- fireplace framing** - 0" to stand-offs (top, rear and sides)
- fireplace finishing** - 4" from the sides of firebox opening
- recessed depth** - 22 1/4 inches
- vent pipe** - 2 inches*
- recessed depth** - 22 1/4 inches

* The first 2 feet of outer 7 inch diameter vent pipe from the appliance must be wrapped in the 1" thick insulation sleeve (supplied).

GENERAL INFORMATION

FOR YOUR SATISFACTION, THIS FIREPLACE HAS BEEN TEST-FIRED TO ASSURE ITS OPERATION AND QUALITY! There must be a 1" air gap in addition to the insulation sleeve. Maximum input is 26,000 BTU/hr for both natural gas and propane. When the fireplace is installed at elevations above 4,500ft, and in the absence of specific recommendations from the local authority having jurisdiction, the certified high altitude input rating shall be reduced at the rate of 4% for each additional 1,000ft. Maximum output for natural gas is 16,150 BTU/hr at an efficiency of 62%; and 16,150 BTU/hr for propane at an efficiency of 62%. Minimum inlet gas supply pressure is 4.5 inches water column for natural gas and 11 inches water column for propane. Maximum inlet gas pressure is 7 inches water column for natural gas and 13 inches water column for propane. Manifold pressure under flow conditions is 3.5 inches water column for natural gas and 10 inches water column for propane.

This fireplace is approved for bathroom, bedroom and bed-sitting room installations and is suitable for mobile home installation. The natural gas model can only be installed in a mobile home that is permanently positioned on its site and fueled with natural gas.

This fireplace may be installed in an aftermarket permanently located, manufactured (mobile) home, where not prohibited by local codes.

This fireplace is only for use with the type of gas indicated on the rating plate. This fireplace is not convertible for use with other gases, unless a certified kit is used.

No external electricity (110 volts or 24 volts) is required for the gas system operation.



We suggest that our gas hearth products be installed and serviced by professionals who are certified in the U.S. by the National Fireplace Institute® (NFI) as NFI Gas Specialists.

CARE OF GLASS, AND PLATED PARTS

Expansion / contraction noises during heating up and cooling down cycles are normal and are to be expected. Change in flame appearance from "HI" to "LO" is more evident in natural gas than in propane.

Do not use abrasive cleaners to clean plated parts. Buff lightly with a clean dry cloth. The glass is 3/16" ceramic glass available from your Napoleon / Wolf Steel Ltd. dealer. **DO NOT SUBSTITUTE MATERIALS.** Clean the glass after the first 10 hours of operation with a recommended gas fireplace glass cleaner. Thereafter clean as required. **DO NOT CLEAN GLASS WHEN HOT!** If the glass is not kept clean permanent discoloration and / or blemishes may result.

VENTING

VENTING LENGTHS & AIR TERMINAL

For safe and proper operation of the fireplace follow the venting instruction exactly.

Deviation from the minimum vertical vent length can create difficulty in burner start-up and/or carboning.

Provide a means for visually checking the vent connection to the fireplace after the fireplace is installed.

Vent lengths that pass through unheated spaces (attics, garages, crawl spaces) should be insulated with the insulation wrapped in a protective sleeve to minimize condensation.

Use only Wolf Steel, Simpson Dura-Vent, Selkirk Direct Temp or American Metal Amerivent venting components.

Wolf Steel, Simpson Dura-Vent, Selkirk Direct Temp and American Metal Amerivent venting systems must not be combined.

Follow the installation procedure provided with the venting components.

For vent systems that provide seals on the inner exhaust flue, only the outer air intake joints must be sealed using a red high temperature silicone (RTV). This same sealant maybe used on both the inner exhaust and outer intake vent pipe joints of all other approved vent systems except for the exhaust vent pipe connection to the fireplace flue collar which must be sealed using the black high temperature sealant Mill Pac. A starter adaptor must be used and may be purchased from the corresponding supplier:

Supplier	4 / 7
DuraVent	W175-0053
Amerivent	4DSC-N2
Direct Temp	4DT-AAN

When using Napoleon venting components, use only approved Wolf Steel Ltd. rigid / flexible vent components with the following termination kits: WALL TERMINAL KIT **GD222R**, or 1/12 TO 7/12 PITCH ROOF TERMINAL KIT **GD110**, 8/12 TO 12/12 ROOF TERMINAL KIT **GD111**, FLAT ROOF TERMINAL KIT **GD112** or PERISCOPE KIT **GD201** (for wall penetration below grade). With flexible venting, in conjunction with the various terminations, use either the 5 foot vent kit **GD220** or the 10 foot vent kit **GD330**. These vent kits allow for either horizontal or vertical venting of the fireplace.

The maximum allowable vertical vent length is 40 feet using flexible venting. The maximum number of allowable 4" vent connections is **three horizontally** or **vertically** (excluding the fireplace and the air terminal connections).

For optimum flame appearance and fireplace performance, keep the vent length and number of elbows to a minimum.

The air terminal must remain unobstructed at all times. Examine the air terminal at least once a year to verify that it is unobstructed and undamaged.

Horizontal runs may have a 0 inch rise per foot in all cases using SIMPSON DURA-VENT or NAPOLEON RIGID OR FLEXIBLE venting components when venting as illustrated in Figures 2a, 2b, and 2c.

When venting, the horizontal run must be kept to a minimum of 16 inches or a maximum of 20 feet. If a 20 foot horizontal run is required, the fireplace must have a minimum vertical rise immediately off the fireplace of 57 inches. FIGURES 2a-c. When terminating vertically, the vertical rise is a minimum 34 inches and a maximum 40 feet above the fireplace. FIGURE 3.

FIGURES 2A-C

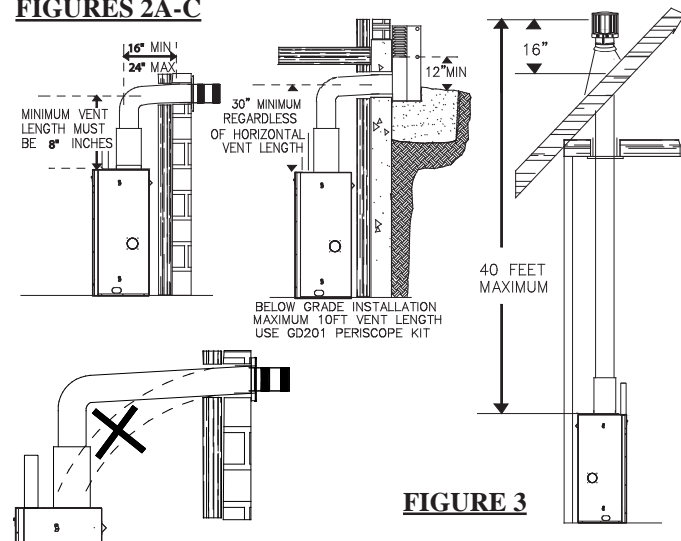

FIGURE 3

For optimum performance, it is recommended that all horizontal runs have a minimum 1/4 inch rise per foot. Provide a means for visually checking the vent connection to the fireplace after the fireplace is installed. Do not allow the inside liner to bunch up on horizontal or vertical runs and elbows. Keep it pulled tight. A 1/4" air gap between the inner and outer liner all around is required for safe operation.

Vent lengths that pass through unheated spaces (attics, garages, crawl space) should be wrapped with a protective insulation sleeve to minimize condensation.

Use a firestop when penetrating interior walls, floor or ceiling.

For safe and proper operation of the fireplace follow the venting instruction exactly.

Deviation from the minimum vertical vent length can create difficulty in burner start-up and/or carboning.

DEFINITIONS

for the following symbols used in the venting calculations and examples are:

- > - greater than
- ≥ - equal to or greater than
- < - less than
- ≤ - equal to or less than

H_T - total of both horizontal vent lengths (H_R) and offsets (H_O) in feet

H_R - combined horizontal vent lengths in feet

H_O - offset factor: .03(total degrees of offset - 90°*) in feet

V_T - combined vertical vent lengths in feet

ELBOW VENT LENGTH VALUES

	feet	inches
1°	0.03	0.5
15°	0.45	6.0
30°	0.9	11.0
45°	1.35	16.0
90°*	2.7	32.0

* the first 90° offset has a zero value and is shown in the formula as -90°

TOP EXIT / HORIZONTAL TERMINATION

FIGURE 4

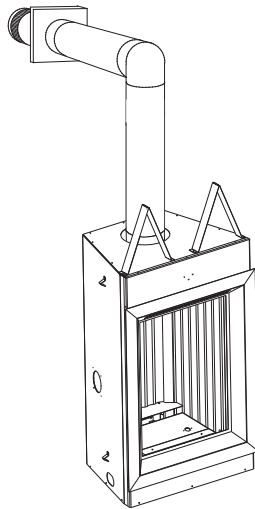

See graph to determine the required vertical rise V_T for the required horizontal run H_T.

For vent configurations requiring more than one 90° elbow, the following formulas apply:

Formula 1: H_T ≤ V_T

Formula 2: H_T + V_T ≤ 40 feet

FIGURE 5

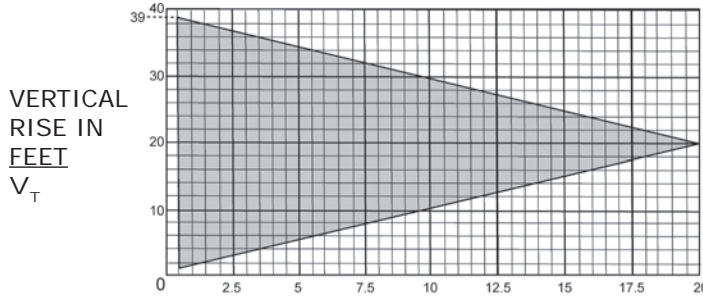
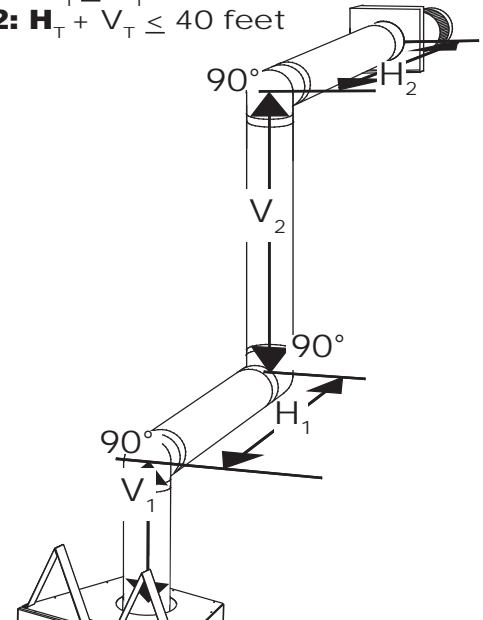

HORIZONTAL VENT RUN PLUS OFFSET IN FEET H_T

The shaded area within the lines represents acceptable values for H_T and V_T.

Example 1:

V₁ = 3 ft

V₂ = 8 ft

V_T = V₁ + V₂ = 3 + 8 = 11 ft

H₁ = 2.5 ft

H₂ = 2 ft

H_R = H₁ + H₂ = 2.5 + 2 = 4.5 ft

H_O = .03(three 90° elbows - 90°) = .03(270° - 90°) = 5.4 ft

H_T = H_R + H_O = 4.5 + 5.4 = 9.9 ft

H_T + V_T = 9.9 + 11 = 20.9 ft

Formula 1: H_T ≤ V_T
9.9 ≤ 11

Formula 2: H_T + V_T ≤ 40 feet
20.9 ≤ 40

Since both formulas are met, this vent configuration is acceptable.

TOP EXIT / HORIZONTAL TERMINATION

when $(H_T) > (V_T)$
 Simple venting configuration (only one 90° elbow)

FIGURE 6

See graph to determine the required vertical rise V_T for the required horizontal run H_T

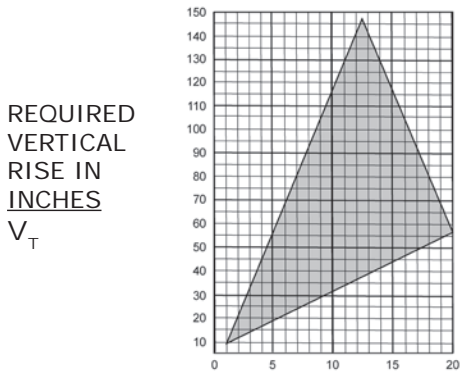
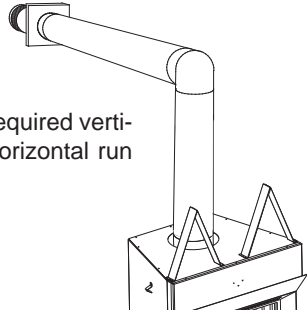

HORIZONTAL VENT RUN PLUS OFFSET IN FEET H_T
The shaded area within the lines represents acceptable values for H_T and V_T .

For vent configurations requiring more than one 90° elbow the following formulas apply:

Formula 1: $H_T \leq 4.2 V_T$

Formula 2: $H_T + V_T \leq 24.75$ feet

Example 2:

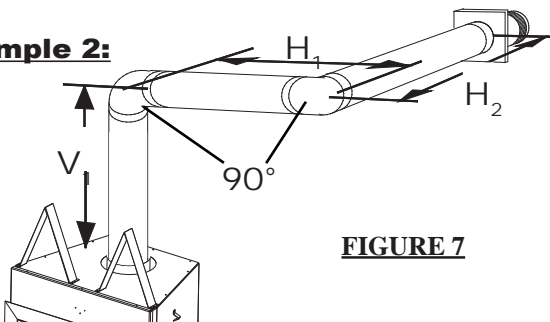

FIGURE 7

$$\begin{aligned} V_1 &= V_T = 6 \text{ ft} \\ H_1 &= 3 \text{ ft} \\ H_2 &= 5 \text{ ft} \\ H_R &= H_1 + H_2 = 3 + 5 = 8 \text{ ft} \\ H_O &= .03(\text{two } 90^\circ \text{ elbows} - 90^\circ) = .03(180^\circ - 90^\circ) = 2.7 \text{ ft} \\ H_T &= H_R + H_O = 8 + 2.7 = 10.7 \text{ ft} \\ H_T + V_T &= 10.7 + 6 = 16.7 \end{aligned}$$

Formula 1: $H_T \leq 4.2 V_T$
 $4.2 V_T = 4.2 \times 6 = 25.2$
 $10.7 \leq 25.2$

Formula 2: $H_T + V_T \leq 24.75$ feet
 $16.7 \leq 24.75$

Since both formulas are met, this vent configuration is acceptable.

Example 3:

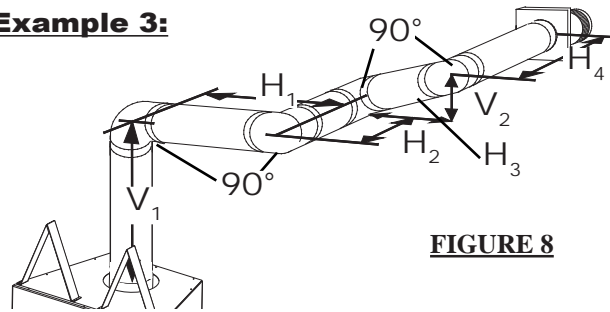

FIGURE 8

$$\begin{aligned} V_1 &= 4 \text{ ft} \\ V_2 &= 1.5 \text{ ft} \\ V_T &= V_1 + V_2 = 4 + 1.5 = 5.5 \text{ ft} \\ H_1 &= 2 \text{ ft} \\ H_2 &= 1 \text{ ft} \\ H_3 &= 1 \text{ ft} \\ H_4 &= 1.5 \text{ ft} \\ H_R &= H_1 + H_2 + H_3 + H_4 = 2 + 1 + 1 + 1.5 = 5.5 \text{ ft} \\ H_O &= .03(\text{four } 90^\circ \text{ elbows} - 90^\circ) = .03(360^\circ - 90^\circ) = 8.1 \text{ ft} \\ H_T &= H_R + H_O = 5.5 + 8.1 = 13.6 \text{ ft} \\ H_T + V_T &= 13.6 + 5.5 = 19.1 \text{ ft} \end{aligned}$$

Formula 1: $H_T \leq 4.2 V_T$
 $4.2 V_T = 4.2 \times 5.5 = 23.1$
 $13.6 \leq 23.1$

Formula 2: $H_T + V_T \leq 24.75$ feet
 $19.1 \leq 24.75$

Since both formulas are met, this vent configuration is acceptable.

TOP EXIT VERTICAL TERMINATION

when $(H_T) \leq (V_T)$

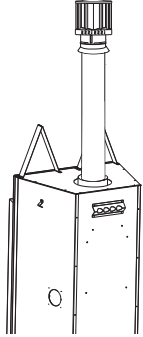
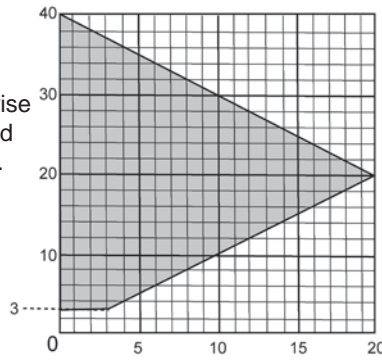

FIGURE 9

See graph to determine the required vertical rise V_T for the required horizontal run H_T .



REQUIRED VERTICAL RISE IN FEET V_T

HORIZONTAL VENT RUN PLUS OFFSET IN FEET H_T

The shaded area within the lines represents acceptable values for H_T and V_T .

For vent configurations requiring more than zero 90° elbow (top exit) or one 90° elbow (rear exit), the following formulas apply:

Formula 1: $H_T \leq V_T$

Formula 2: $H_T + V_T \leq 40$ feet

TOP VERTICAL TERMINATION

when $(H_T) > (V_T)$

Simple venting configurations

FIGURE 10

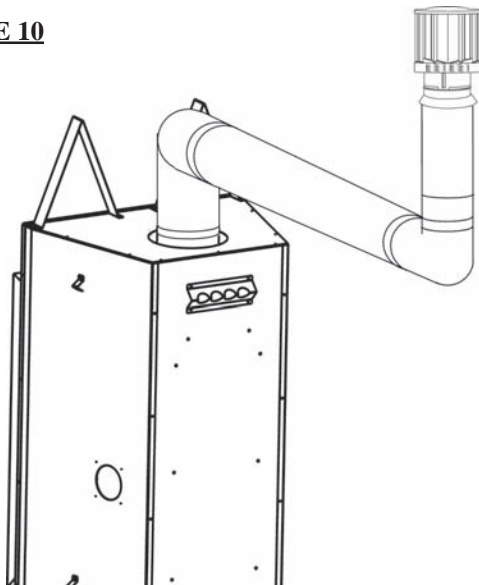

See graph to determine the required vertical rise V_T for the required horizontal run H_T .

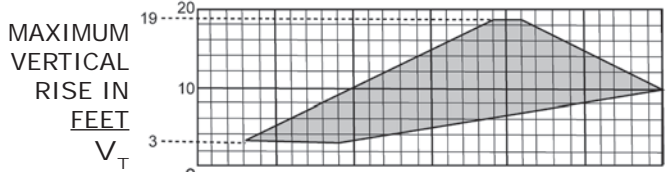

HORIZONTAL VENT RUN PLUS OFFSET IN FEET H_T
The shaded area within the lines represents acceptable values for H_T and V_T .

For vent configurations requiring more than two 90° elbow (top exit) or one 90° elbow (rear exit), the following formulas apply:

Formula 1: $H_T \leq 3V_T$

Formula 2: $H_T + V_T \leq 40$ feet

Example 7:

$V_1 = 2$ ft
 $V_2 = 1$ ft

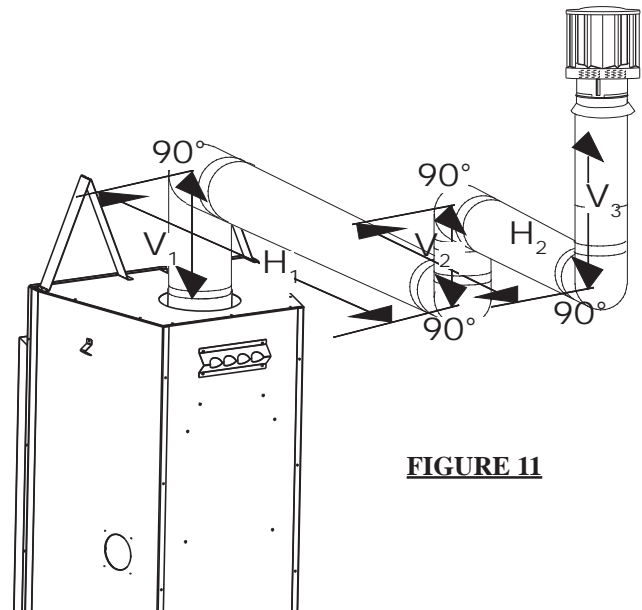

FIGURE 11

$V_3 = 1.5$ ft
 $V_T = V_1 + V_2 + V_3 = 2 + 1 + 1.5 = 4.5$ ft
 $H_1 = 6$ ft
 $H_2 = 2$ ft
 $H_R = 8.1$ ft
 $H_T = H_R + H_O = 8 + 8.1 = 16.1$ ft
 $H_T + V_T = 16.1 + 4.5 = 20.6$ ft

Formula 1: $H_T \leq 3V_T$
 $3V_T = 3 \times 4.5 = 13.5$
 $16.1 > 13.5$

Since this formula is not met, this vent configuration is **unacceptable**.

Formula 2: $H_T + V_T \leq 40$ feet
 $20.6 \leq 40$

Since only formula 2 is met, this vent configuration is unacceptable and a new fireplace location or vent configuration will need to be established to satisfy both formulas.

AIR TERMINAL LOCATIONS

FIGURE 12

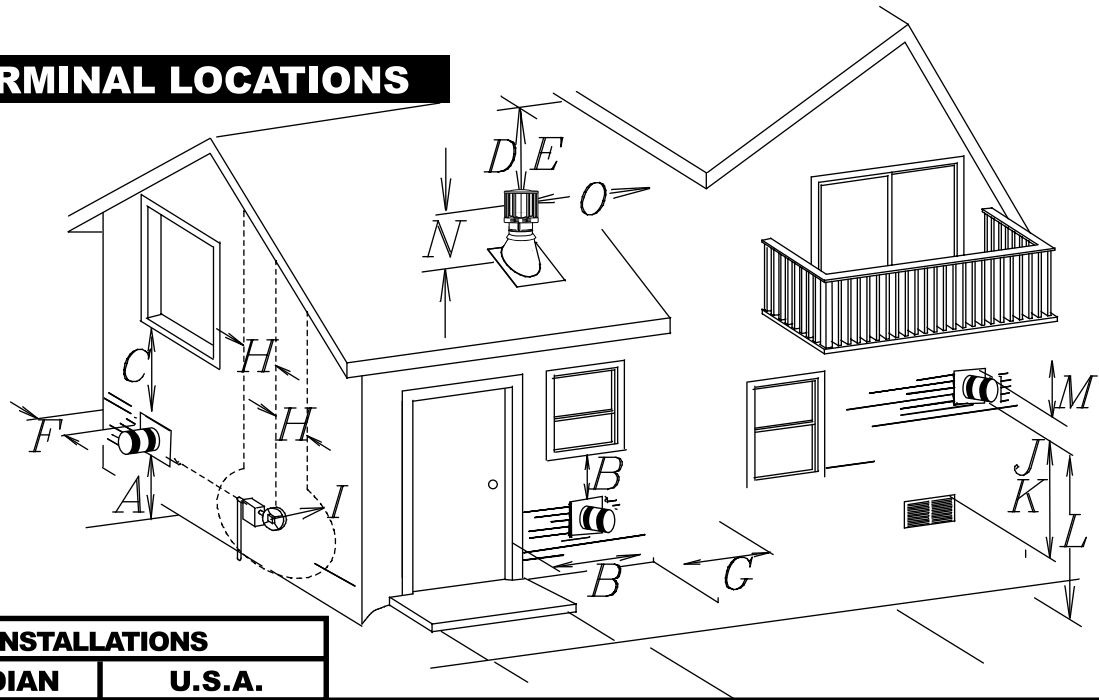

INSTALLATIONS			
	CANADIAN	U.S.A.	
A	12 INCHES	12 INCHES	Clearance above grade, veranda porch, deck or balcony.
B	12 INCHES	9 INCHES	Clearance to windows or doors that open.
C	12 INCHES*	12 INCHES*	Clearance to permanently closed windows.
D	18 INCHES**	18 INCHES**	Vertical clearance to ventilated soffit located above the terminal within a horizontal distance of 2 feet from the centerline of the terminal.
E	12 INCHES**	12 INCHES**	Clearance to unventilated soffit.
F	0 INCHES	0 INCHES	Clearance to an outside corner wall.
G	0 INCHES***	0 INCHES***	Clearance to an inside <i>non</i> -combustible corner wall or protruding <i>non</i> -combustible obstructions (chimney, etc.).
	2 INCHES***	2 INCHES***	Clearance to an inside combustible corner wall or protruding combustible obstructions (vent chase, etc.).
H	3 FEET	3 FEET****	Clearance to each side of the centerline extended above the meter / regulator assembly to a maximum vertical distance of 15ft.
I	3 FEET	3 FEET****	Clearance to a service regulator vent outlet.
J	12 INCHES	9 INCHES	Clearance to a non-mechanical air supply inlet to the building or a combustion air inlet to any other appliance.
K	6 FEET	3 FEET†	Clearance to a mechanical air supply inlet.
L	7 FEET‡	7 FEET****	Clearance above a paved sidewalk or paved driveway located on public property unless fitted with a heat shield kit GD-301.
M	12 INCHES††	12 INCHES****	Clearance under a veranda, porch, deck or balcony.
N	16 INCHES	16 INCHES	Clearance above the roof.
O	2 FEET†*	2 FEET†*	Clearance from an adjacent wall including neighbouring buildings.

* Recommended to prevent condensation on windows and thermal breakage
 ** It is recommended to use a heat shield and to maximize the distance to vinyl clad soffits.
 *** The periscope GD-201 requires a minimum 18 inches clearance from an inside corner.
 **** This is a recommended distance. For additional requirements check local codes.
 † Three feet above if within 10 feet horizontally.
 ‡ A vent shall not terminate directly above a sidewalk or paved driveway that is located between two single family dwellings and serves both dwellings.
 †† Permitted only if the veranda, porch, or deck is fully open on a minimum of two sides beneath the floor.
 †* Recommended to prevent recirculation of exhaust products. For additional requirements check local codes.

INSTALLATION

WALL AND CEILING PROTECTION

For optimum performance it is recommended that all horizontal runs have a minimum $\frac{1}{4}$ inch rise per foot using flexible venting.

For safe and proper operation of the fireplace, follow the venting instructions exactly.

HORIZONTAL TERMINATION: A clearance to combustibles of 2" must be maintained during the first 24" of venting when penetrating combustible walls. The firestop spacer (W500-0292) supplied with the unit should be used to maintain this clearance. The first two feet of outer 7" diameter vent pipe, from the appliance must be wrapped in the 1 inch thick insulation sleeve (supplied) as well as having a 1 inch air gap. Thereafter a 1" clearance to combustibles may be maintained using firestop spacer (W615-0044 for use with flexible venting or rigid venting.)

VERTICAL INSTALLATION

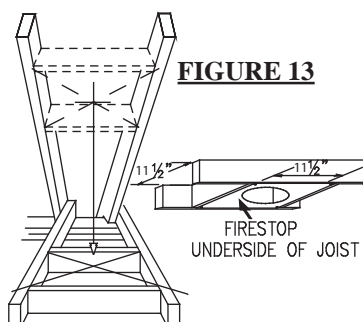

FIGURE 13

This application occurs when venting through a roof. Installation kits for various roof pitches are available from your Napoleon dealer. See Accessories to order the specific kit required.

1. Determine the air terminal location, cut and frame $9\frac{1}{2}$ or $11\frac{1}{2}$ inch openings in the ceiling and the roof to provide the minimum clearance between the fireplace pipe / liner and any combustible material. Try to center the exhaust pipe location midway between two joist to prevent having to cut them. Use a plumb bob to line up the center of the openings.

ing and the roof to provide the minimum clearance between the fireplace pipe / liner and any combustible material. Try to center the exhaust pipe location midway between two joist to prevent having to cut them. Use a plumb bob to line up the center of the openings.

DO NOT FILL THIS SPACE WITH ANY TYPE OF MATERIAL.

A vent pipe shield will prevent any materials such as insulation, from filling up the 1" air space around the pipe. Nail headers between the joist for extra support.

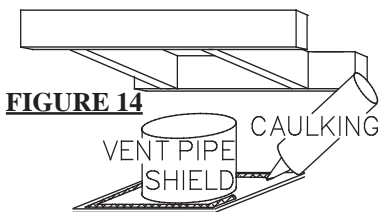

FIGURE 14

2. Apply a bead of caulking (not supplied) to the framework or to the Wolf Steel vent pipe shield plate or equivalent (in the case of a finished ceiling), and secure over the opening in the ceiling. A firestop must be placed on the bottom of each framed opening in a roof or ceiling that the venting system passes through. Apply a bead of caulk all around and place a firestop spacer over the vent shield to restrict cold air from being drawn into the room or around the fireplace. Ensure that both spacer and shield maintain the required clearance to combustibles. Once the vent pipe / liner is installed in its final position, apply sealant between the pipe / liner and the firestop spacer.

3. In the attic, after the pipe / liner has been installed, slide the vent pipe collar down to cover up the open end of the shield and tighten. This will prevent any materials, such as insulation, from filling up the 1" air space around the pipe.

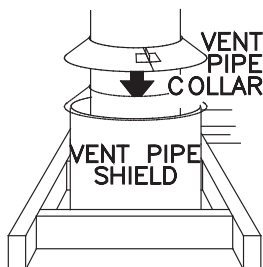

FIGURE 15

HORIZONTAL INSTALLATION

This application occurs when venting through an exterior wall. Having determined the air terminal location, cut and frame a hole in an exterior wall with a minimum rectangle opening of 12" x 11".

IMPORTANT: For optimum performance, The stove pipe should rise $\frac{1}{4}$ " per foot of run.

1. Assemble the shield to the spacer as shown, using the 3 shorter screws supplied.

The shield is meant to protect combustible materials within the wall. If the shield is deeper than the combustible portion of the wall, cut to fit.

2. Apply a bead of caulking all around and place the firestop spacer over the framework to restrict cold air from being drawn into the room or around the stove. Ensure that both spacer and shield maintain the required clearance to combustibles. Secure the spacer in place using the 4 longer screws supplied. Once the vent pipe is installed in its final position, apply sealant between the pipe and the firestop spacer.

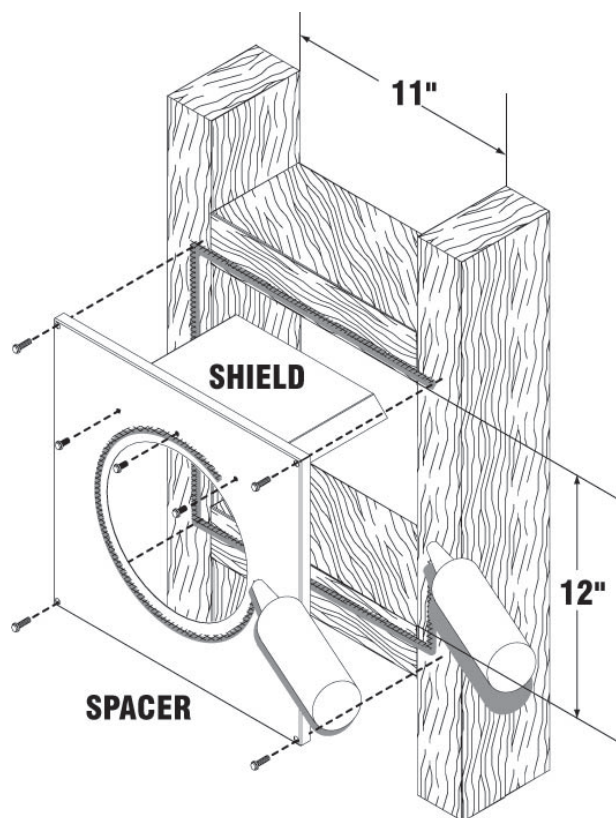

USING FLEXIBLE VENT COMPONENTS

Use only approved aluminum flexible liner kits marked:



“Wolf Steel Approved Venting” as identified by the stamp only on the 7” outer liner.

For safe and proper operation of the fireplace, follow the venting instructions exactly.

All inner exhaust and outer intake vent pipe joists may be sealed using either Red RTV high temp silicone sealant or Black high temp Mill Pac with the exception of the fireplace exhaust flue collar which must be sealed using Mill Pac (not supplied).

Spacers are attached to the inner flex liner at predetermined intervals to maintain a 1-1/4” air gap to the outer flex liner. These spacers must not be removed.

HORIZONTAL AIR TERMINAL INSTALLATION

1. Cut or frame a hole in an exterior wall with a minimum round or square opening of 11 1/2” W x 11 1/2” H. Secure the firestop spacer over the opening to the interior wall. Secure the terminal to the terminal extension plate if required (see figure 18). The cover plate of the GD-222R terminal is 13”x13” and will cover the 11 1/2” x 11 1/2” opening but if the opening is made any larger - the terminal extension plate is required.

2. Stretch the 4” diameter aluminum flexible liner to the required length taking into account the additional length needed for the finished wall surface. Slip the liner a minimum of 2” over the inner sleeve of the air terminal and secure with 3 #8 screws. Apply a heavy bead of the high temperature sealant.

3. Using the 7” diameter flexible aluminum liner, slide over the outer combustion air sleeve of the air terminal and secure with 3 #8 screws. Seal as before.

4. Insert the liners through the firestop maintaining the required clearance to combustibles. Secure to the exterior

wall and make weather tight by

5. Apply a heavy bead of the high temperature sealant, (W573-0007 not provided), to the inside of the 4” liner approximately 1” from the end. Slip the liner a minimum of 2” over the fireplace vent collar and secure with 3 #8 screws.

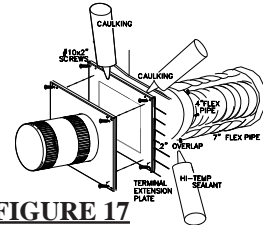

FIGURE 17

6. Using the 7” diameter flexible aluminium liner, apply sealant, slide a minimum of 2” over the fireplace combustion air collar and secure with 3 #8 screws.

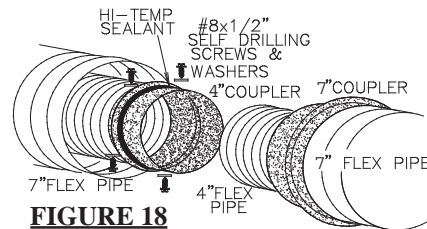
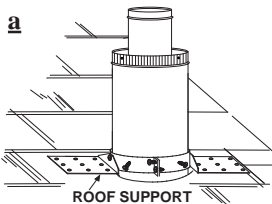

FIGURE 18

VERTICAL AIR TERMINAL INSTALLATION

1. Fasten the roof support to the roof using the screws provided. The roof support is optional. In this case the venting is to be adequately supported using either an alternate method suitable to the authority having jurisdiction or the optional roof support. (Fig.a)



2. Stretch the inner aluminum flex liner to the required length. Slip the liner a minimum of 2” over the inner sleeve of the air terminal connector and secure with 3 #8 screws. Seal using a heavy bead of the high temperature sealant. (Fig.b)

FIGURE 19a,b&c

3. Repeat using the outer aluminum flex liner. (Fig.b)

4. Thread the air terminal connector / liner assembly down through the roof. The air terminal must be located vertically and plumb. Attach the air terminal connector to the roof support, ensuring that the top of the air terminal is 16” above the highest point that it penetrates the roof. (Fig.c) **If the attic space is tight, we recommend threading the Wolf Steel vent pipe collar or equivalent loosely onto the air terminal assembly as it is passed through the attic.**

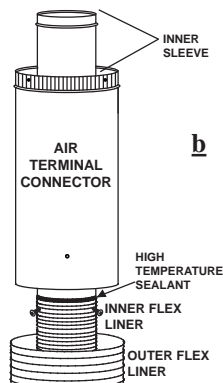

DO NOT CLAMP THE FLEXIBLE ALUMINIUM LINER.

5. Remove nails from the shingles, above and to the sides of the chimney. Place the flashing connector over the air terminal connector leaving a min. 3/4” of the air terminal connector showing above the top of the flashing. Slide the flashing underneath the sides and upper edge of the shingles. Ensure that the air terminal connector is properly centred within the flashing, giving a 3/4” margin all around. Fasten to the roof. Do not nail through the lower portion of the flashing. Make weather-tight by sealing with caulking. Where possible, cover the sides and top edges of the flashing with roofing material. (Fig.c)

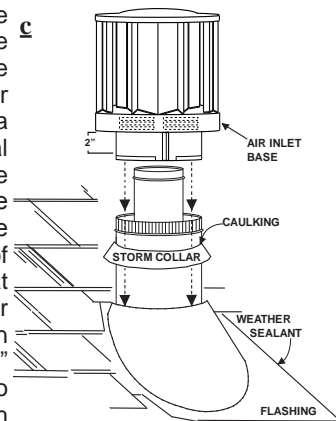

6. Aligning the seams of the terminal and air terminal connector, place the terminal over the air terminal connector making sure the liner goes into the hole in the terminal. Secure with the three screws provided. (Fig.c)

7. Apply a heavy bead of weatherproof caulking 2 inches above the flashing. Note: Maintain a minimum 2” space between the air inlet base and the storm collar. Install the storm collar around the air terminal connector and slide down to the caulking. Tighten to ensure that a weather-tight seal between the air terminal connector and the collar is achieved. (Fig.c)

FIREPLACE VENT CONNECTION

1. Install the 4" diameter aluminium flexible liner to the fireplace. Secure with 3 screws and flat washers. Seal the joint and screw holes using the high temperature sealant (W573-0007 not provided).
2. Install the 7" diameter aluminium flexible liner to the fireplace. Attach and seal the joints.

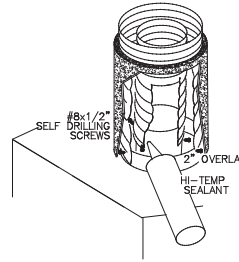

FIGURE 20

USING RIGID VENT COMPONENTS

The vent system must be supported approximately every 3 feet for both vertical and horizontal runs. Use Wolf Steel vent spacers or equivalent every 3 feet and either side of each elbow to maintain the minimum 1¼" clearance between the outer and inner vent pipes. Use Wolf Steel support ring assembly or equivalent noncombustible strapping to maintain the minimum clearance to combustibles for both vertical and horizontal runs.

All inner exhaust and outer intake vent pipe joists may be sealed using either Red RTV high temp silicone sealant or Black high temp Mill Pac with the exception of the fireplace exhaust flue collar which must be sealed using Mill Pac (not supplied).

HORIZONTAL AIR TERMINAL INSTALLATION

1. Move the fireplace into position. Measure the vent length required between terminal and fireplace taking into account the additional length needed for the finished wall surface and any 1¼" overlaps between venting components.

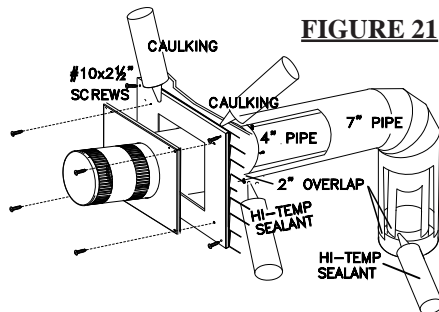

FIGURE 21

2. Apply high temperature sealant (W573-0007 not provided) to the outer edge of the 4" inner collar of the fireplace. Attach the first vent component and secure using 3 self tapping screws. Repeat using 7" piping.
3. Holding the air terminal (with the air deflectors to the top and the lettering in an upright, readable position) insert the terminal into both vent pipes with a twisting motion to ensure that both the terminal sleeves engage into the vent pipes and sealant. Secure the terminal to the exterior wall and make weather tight by sealing with caulking (not supplied).

EXTENDED HORIZONTAL AIR TERMINAL INSTALLATION

1. Follow the instructions for "Horizontal Air Terminal Installations", items 1 to 3.

2. Continue adding components alternating inner and outer venting. Ensure that all 4" venting and elbows have sufficient vent spacers attached and each component is securely fastened to the one prior. Attach the 4" telescopic sleeve to the vent run.

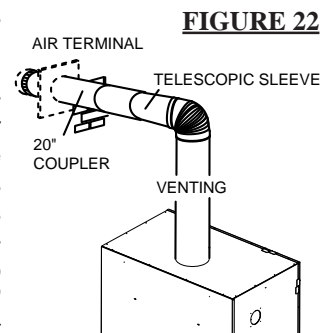

FIGURE 22

- Repeat using a 7" telescopic sleeve. Secure and seal as before. To facilitate completion, attach 4" and 7" couplers to the air terminal.

3. Install the air terminal. See item 3 of the Horizontal Air Terminal Installation. Extend the 4" telescopic sleeve; connect to the air terminal assembly. Fasten with self tapping screws and seal. Repeat using the 7" telescopic sleeve.

VERTICAL VENTING INSTALLATION

1. Move the fireplace into position.

2. Fasten the roof support to the roof using the screws provided. The roof support is optional. In this case the venting is to be adequately supported using either an alternate method suitable to the authority having jurisdiction or the optional roof support.

3. Apply high temperature sealant to the outer edge of the inner sleeve of the air terminal. Slip a 4" diameter coupler a minimum of 2" over the sleeve and secure using 3 screws.

4. Apply high temperature sealant to the outer edge of the of the outside sleeve of the air terminal. Slip a 7" diameter coupler over the sleeve and secure as before. Trim the 7" coupler even with the 4" coupler end.

5. Thread the air terminal pipe assembly down through the roof support and attach, ensuring that a minimum 16" of air terminal will penetrate the roof when fastened. The air terminal must be located vertically and plumb.

6. Remove nails from the shingles, above and to the sides of the chimney. Place the flashing over the air terminal and slide it underneath the sides and upper edge of the shingles. Ensure that the air terminal is properly centred within the flashing, giving a 3/4" margin all around. Fasten to the roof. Do NOT nail through the lower portion of the flashing. Make weather-tight by sealing with caulking. Where possible, cover the sides and top edges of the flashing with roofing material.

7. Apply a heavy bead of waterproof caulking 2 inches above the flashing. Slide the storm collar around the air terminal connector and down to the caulking. Tighten to ensure that a weather-tight seal between the air terminal and the collar is achieved.

8. Continue adding rigid venting sections, sealing and securing as above. Attach a 4" collapsed telescopic pipe to the last section of rigid piping. Secure with screws and seal. Repeat using a 7" telescopic pipe.

9. Run a bead of high temperature sealant around the outside of the 4" collar on the fireplace. Pull the adjustable pipe a minimum of 2" onto the collar. Secure with 3 screws. Repeat with the 7" telescopic pipe.

10. In the attic, slide the vent pipe collar down to cover up the open end of the shield and tighten. This will prevent any materials, such as insulation, from filling up the 1" air space around the pipe.

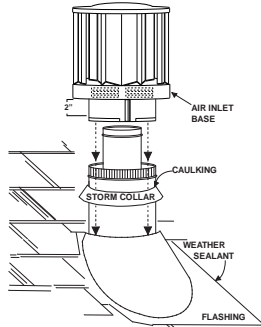

FIGURE 23

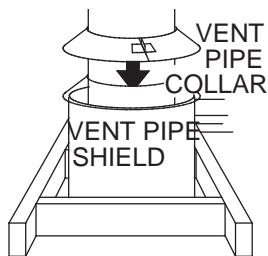

FIGURE 24

GAS INSTALLATION

Proceed once the vent installation is complete.

Note : All gas connections must be contained within the fireplace when complete.

1. The fireplace is designed to accept a 1/2" gas supply line. The fireplace is equipped with a 1/2" manual shut-off valve, and an 18" listed flexible gas connector.

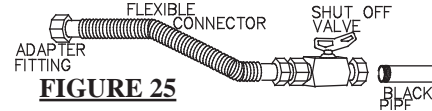

FIGURE 25

2. The access to the gas inlet is located on the right side of the outer shell.

3. The flex connector and shut off must all be within the outer shell.

4. When flexing any gas line, support the gas valve so that the lines are not bent.

5. Check for gas leaks by brushing on a soap and water solution. **Do not use open flame.**

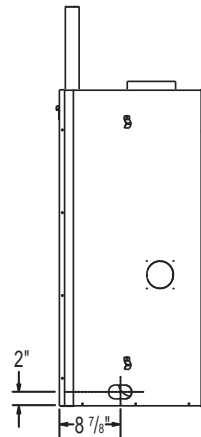
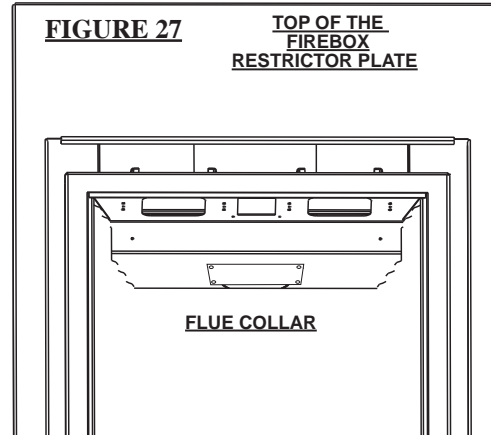

FIGURE 26

RESTRICTING VERTICAL VENTS



Vertical terminations may display a very active flame. If this appearance is not desirable, the vent exit must be restricted using restrictor plate, W500-0205. This reduces the velocity of the exhaust gases, slowing down the flame pattern and creating a more traditional appearance.

The plate has a series of holes to allow for adjustment. Remove the two screws on either side of the exhaust collar inside the firebox. Install the plate in the desired set of holes, then replace the screws.

It is recommend to secure in the third set of holes which causes the greatest amount of restriction for vent length between 15 and 30 feet.

FRAMING

It is best to frame your fireplace after it is positioned and the vent system is installed. Use 2x4's and frame to local building codes.

Note: In order to avoid the possibility of exposed insulation or vapour barrier coming in contact with the fireplace body, it is recommended that the walls of the fireplace enclosure be "finished" (ie: drywall/sheetrock), as you would finish any other outside wall of a home. This will ensure that clearance to combustibles is maintained within the cavity.

It is not necessary to install a hearth extension, but the fireplace should be raised to be flush with either the hearth or the finished floor.

When roughing in the fireplace, raise the fireplace to accommodate for the thickness of the finished floor materials, i.e. tile, carpeting, hard wood, which if not planned for will interfere with the removal of the hearth strip, which must be removed to access the firebox.

Objects placed in front of the fireplace should be kept a minimum of 48" away from the front face.

For convenience, the stand-offs have been shipped flat. Before framing, ensure the stand-offs are opened and screwed in place.

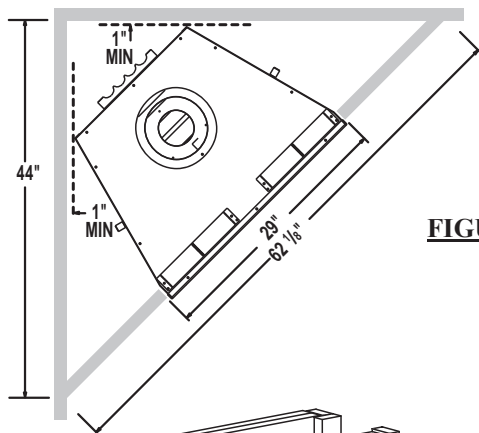

FIGURE 28

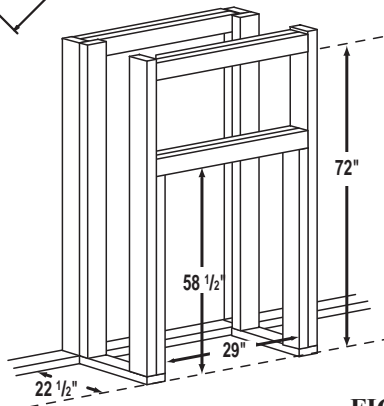
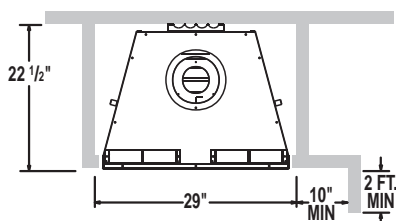

FIGURE 29



CLEARANCE TO COMBUSTIBLES

MAINTAIN THESE MINIMUM CLEARANCES TO COMBUSTIBLES:

- Fireplace framing - 0" to stand-offs (top, rear & sides)
- Fireplace finishing - 4" to sides of fireplace opening.
- 21 3/4" to top of fireplace opening.

FIGURE 30

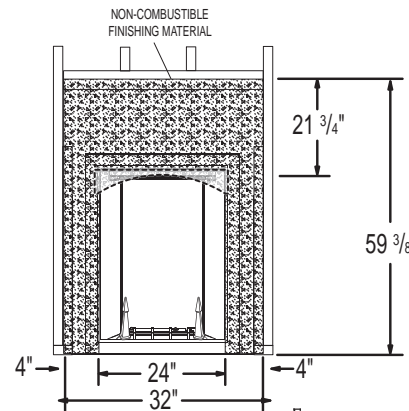

Non-combustible finishing material (ie: cement board, brick, stone, tile) may be used to finish the front of the unit.

IMPORTANT:

The Park Ave. requires a minimum inside enclosure height of 72". For temperature requirements, this area must be left unobstructed.

It is recommended that the enclosure be ventilated at the top and bottom to circulate the hot air.

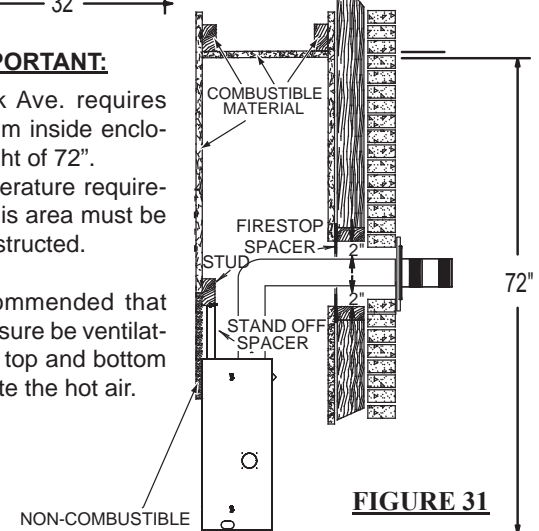

FIGURE 31

WARNING

Facing and/or finishing material must never overhang into the fireplace opening.

Do not distort or force the frame kit components.

When using a rough finish material (i.e.; stone), maintain a 1/4" - 1/2" border from the framing components.

MANTLE CLEARANCES

Combustible mantle clearance can vary according to the mantle depth. Use the graph to help evaluate the clearance needed.

FIGURE 32

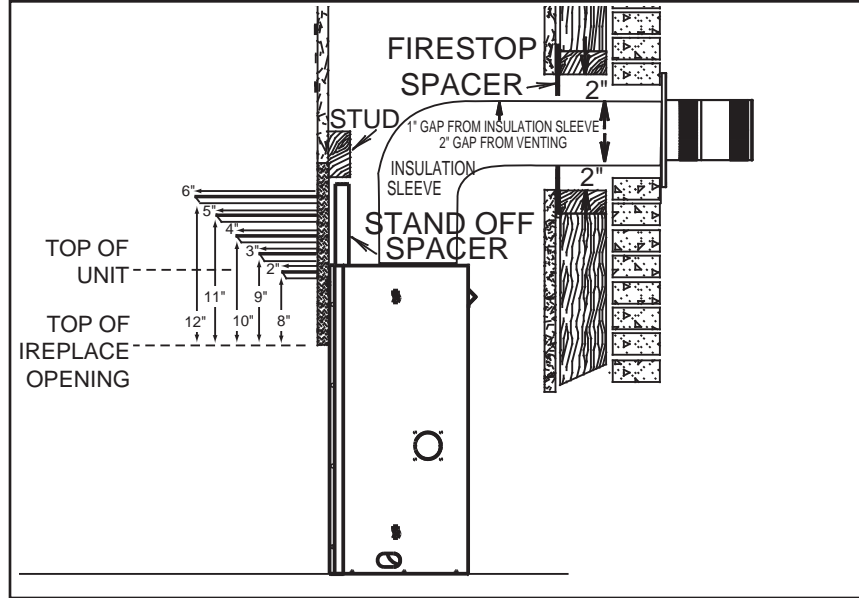
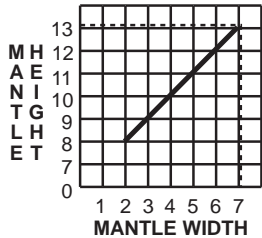

ELECTRICAL CONNECTION

Do NOT use the fireplace if any part has been under water.

Call a qualified service technician IMMEDIATELY to have the fireplace inspected for damage to the electrical circuit.

If access to the control area is necessary **BEFORE INSTALLATION**, remove the access panel.

The access panel must be re-installed before operating the unit.

HARD WIRING CONNECTION

It is necessary to hard wire this fireplace.

Permanently framing the fireplace with an enclosure, requires the fireplace junction box to be hardwired.

This fireplace must be electrically connected and grounded in accordance with local codes. In the absence of local codes, use the current CSA C22.1 CANADIAN ELECTRICAL CODE in Canada or the ANSI/NFPA 70-1996 NATIONAL ELECTRICAL CODE in the United States.

SCHEMATIC

FIGURE 33

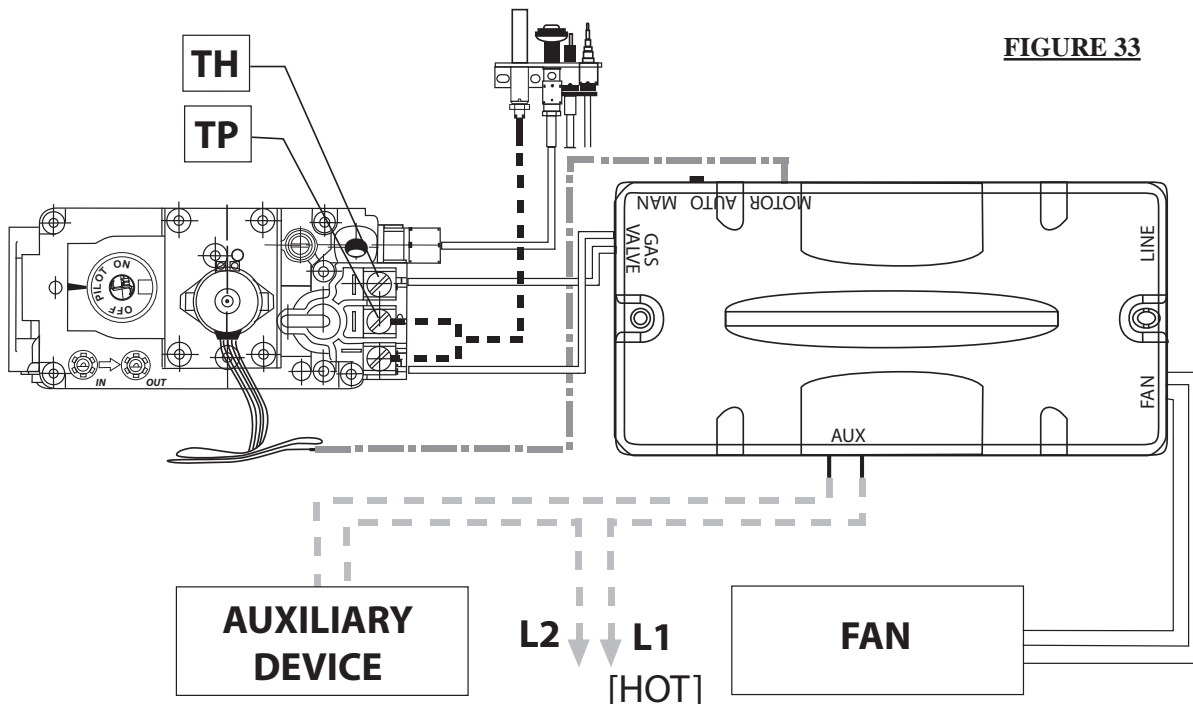

FINISHING

DOOR REMOVAL

Before the glass door can be removed, the optional front must be removed.

The glass door is secured to the top front edge of the firebox. Pull the handles of the latches forward, then lift the hooks out from the slots in the door frame to release the top of the door. Next, pivot forward until the top edge of the door clears the front of the fireplace. Next gripping the sides of the door lift the door out from the retainer along the bottom of the door.

FIGURE 34

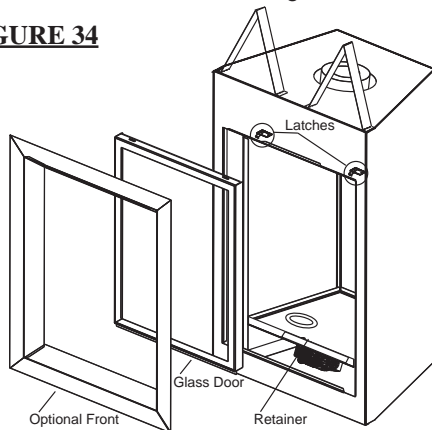

**Decorative brick panels must be installed before the logs.
See installation instructions supplied with the panel kit.**

LOG SHIPPING BRACKET

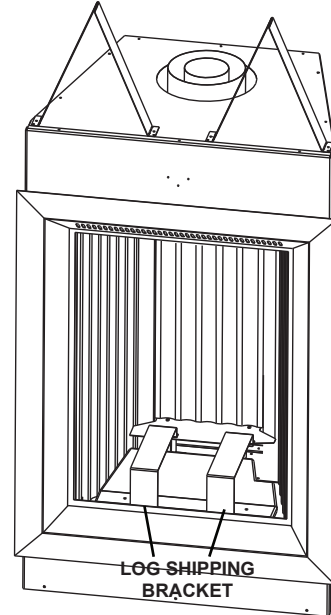

FIGURE 35

Before installing the logs, you must first remove the log shipping brackets. Lift up to remove.

LOG PLACEMENT

PHAZER™ logs, exclusive to Napoleon Fireplaces, provide a unique and realistic glowing effect that is different in every installation.

FIGURE 36 A-F

1. Place the rear log #1 onto the locating studs along the back edge of the PHAZERAMIC™ burner.



2. Position log #2 in the 2 locating holes behind the andirons.



3. Place log #3, with the charred branch facing inward. Position the pin in log #3 into the hole on the left of the log #2.



4. Place log #4 with the charred branch facing inward. Position the pin in log #4 into the hole on the right of log #2.



5. Place log #5 so the locating hole on the bottom of the log sits on the screw and spacer.

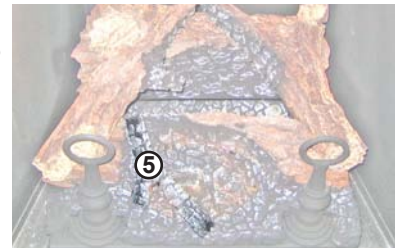

6. Finally, align the rectangular peg on log #6 with the notch on the front right portion of the burner.

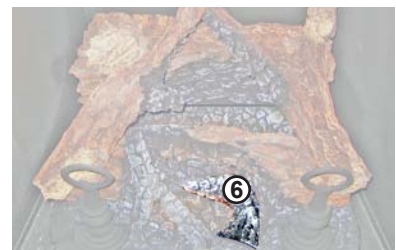

GLOWING EMBERS

Glowing embers are NOT recommended. The burner has been designed to achieve maximum glow without embers.

BLOWER REPLACEMENT

The Napoleon PARK AVENUE comes equipped with a heat circulating blower. The blower is pre-wired and is controlled by the remote control supplied with the unit. For control details, see operation. Pg. 22.

Drywall dust will penetrate into the blower bearings, causing irreparable damage. Care must be taken to prevent drywall dust from coming into contact with the blower or its compartment. Any damage resulting from this condition is not covered by the warranty policy.

1. Turn off the power to the fireplace.
2. Turn off the gas valve.

FIGURE 37

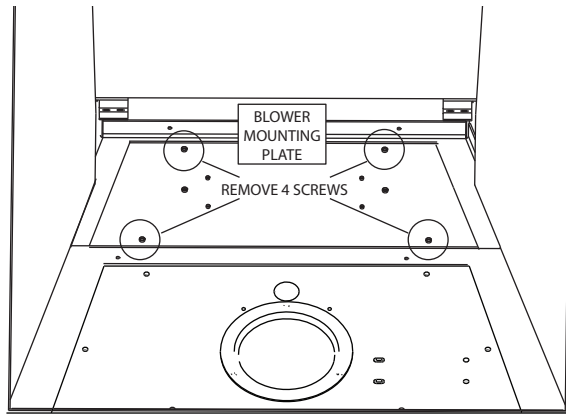

3. Remove the glass door, logs, rear log supports, brick panels, air deflector, burner assembly, panel support, panel support bracket.

4. The blower mounting plate can now be removed. Remove the four screws that secure the plate to the firebox base.

5. The blower is secured to the firebox. Disconnect the wire connectors before attempting to remove the blower from the firebox.

6. Remove the two screws securing the blower and lift through blower access opening.

FIGURE 38

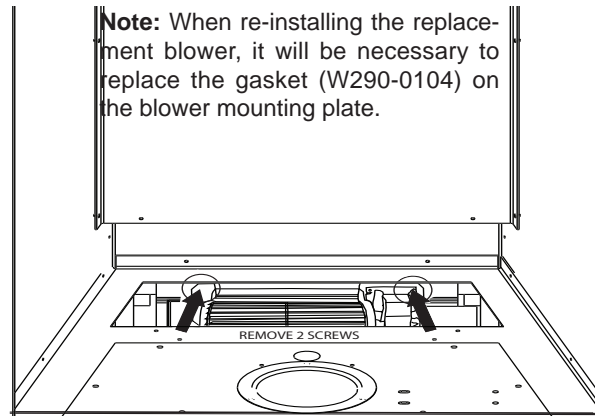

NIGHT LIGHT REPLACEMENT

Your PARK AVENUE comes equipped with our "Night Light". The light has been pre-wired and is controlled from the remote control.

If in the event the lamp or lens needs to be replaced, follow the instructions below.

Unplug the wireharness / transformer from the junction box inside the fireplace.



FIGURE 39

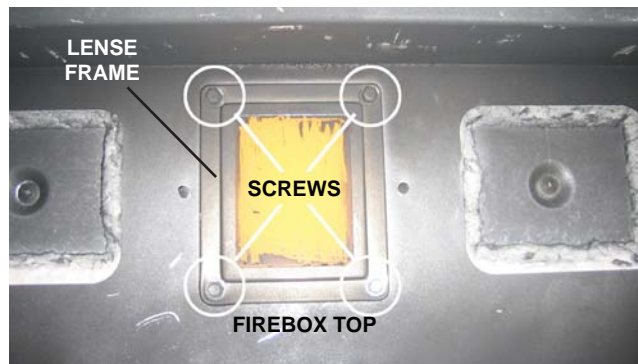
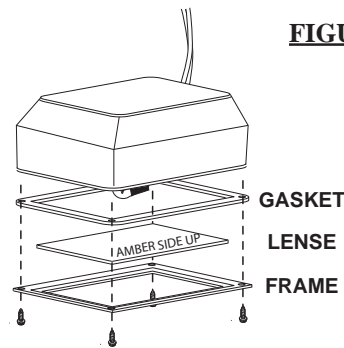

FIGURE 40

FIGURE 41



Remove the four screws that secure the lens frame. This frame retains the glass lens. The lamp can now be accessed.

Note: Do not handle the lamp (bulb) with bare fingers, protect with a clean dry cloth.

The lamp will pull straight out of the socket. Replace with Wolf Steel parts only, as lamp and lens are special "high temperature" products.

When re-installing, ensure integrity of gasket seal.

THE FIREBOX MUST BE SEALED.

Over tightening the screws could break the lens.

"Light Leakage" from the upper area may be observed.

The holes in the lamp housing are necessary for ventilation and must not be covered.

DECORATIVE BRICK PANEL INSTALLATION

1. Carefully remove the glass door and all logs. (Refer to the installation manual)

2. Remove the two screws holding the front portion of the rear air deflector. Remove the pilot shield by removing the two screws as illustrated. (Fig. 42)



3. Remove the 3 screws holding the burner down and carefully remove the burner. (Fig. 43)

4. Install the right brick panel by sliding the bottom edge of the panel down the right firebox side then pivot the top of the panel into place against the firebox wall. Hold in place with the brick retainers. (Fig. 44)

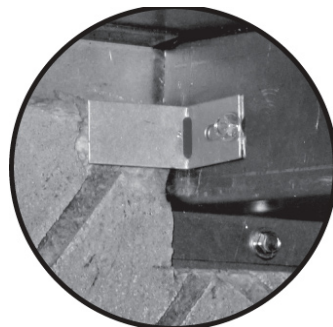

5. Rest the bottom edge of the rear panel on top of the rear portion of the air deflector at the back of the firebox and push into place. The rear panel is held in place when both side panels are in position.

6. Install the left brick panel using the same method described in step 4.

7. Replace the burner, air deflector, logs and glass door.

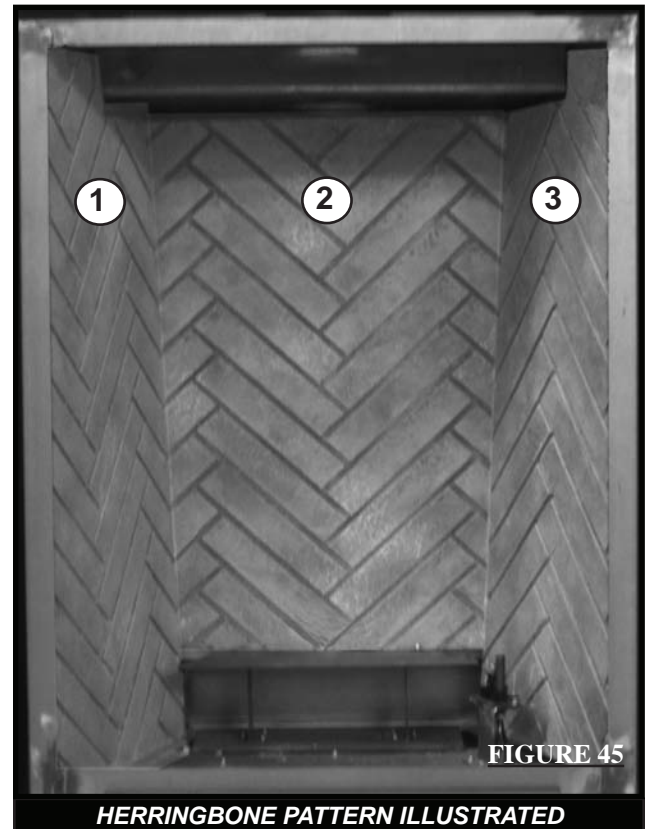

Note: Due to the brittle material of the bricks, care must be taken not to bend or force them into place.

Note: Refractory panels require a 24 hour curing period on a low flame.

When shipped, the brick panels range in varying shades of tan. During initial use, the panels will emit a slight odor for a few hours. This is a normal condition that will not occur again. Simply open a window to sufficiently ventilate the room. The appearance of the panels will permanently lighten in colour with use.

AFK / WI FACE KIT INSTALLATION

1. Attach screw and spacer as illustrated in Fig. 46 to the bottom of both sides of the front housing.

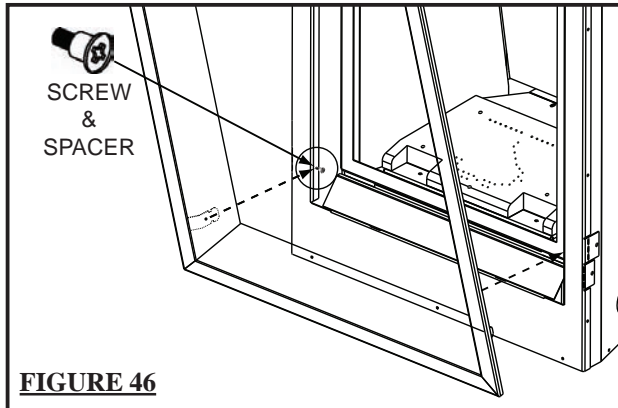

2. Attach the face plate bracket provided to the top edge of the front housing using 2 #8 - 1/2" truss head screws as illustrated in Fig. 47.

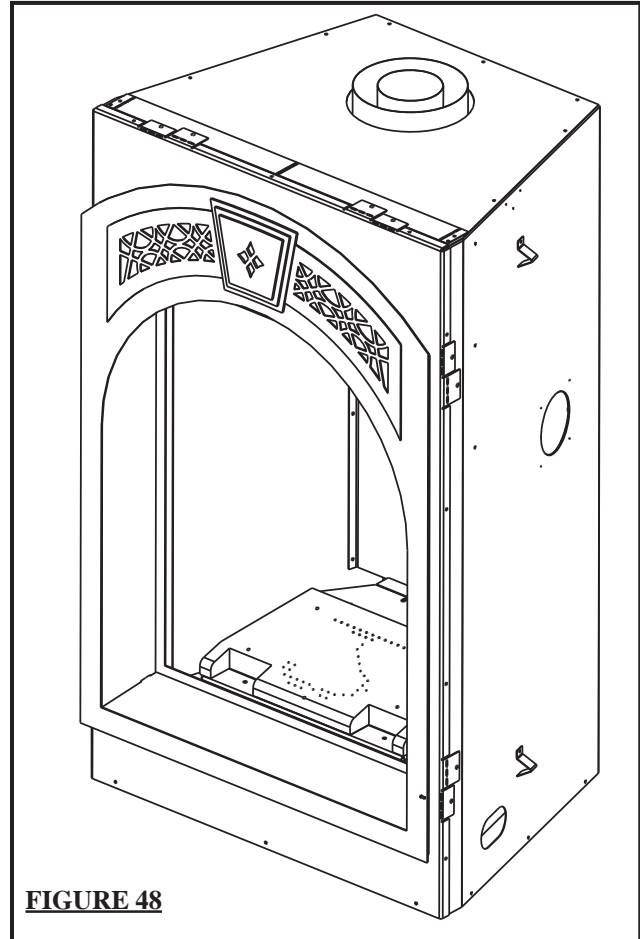
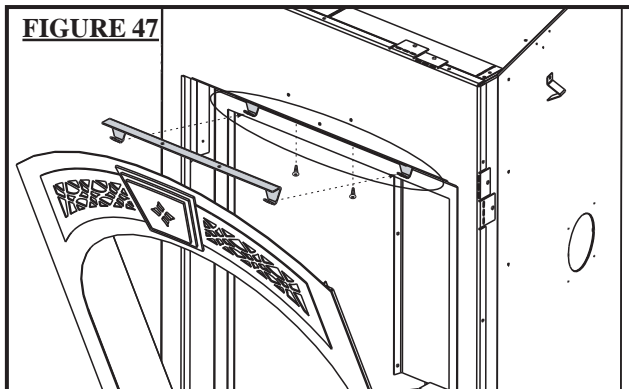

3. Lift and hook the faceplate over the spacers. Then push the top of the faceplate back until it comes in contact with the face plate bracket, then secure on the underside by using the 2 1/4-20 screws provided as illustrated in Fig. 49.

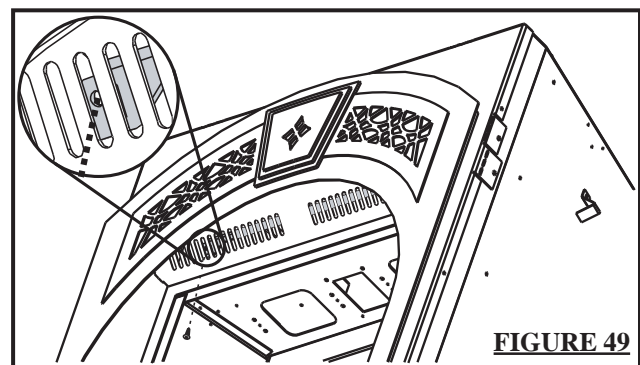

NOTE: A 1/4" gap must be maintained between the front and all finishing material due to regular removal.

REMOTE, RECEIVER AND VALVE ACCESS

BURNER ASSEMBLY REMOVAL

1a. Rectangular Front Removal

Pull on the top of the optional front away from the fireplace until the male portion of the latch disengages. Tilt forward slightly and lift from the 2 shoulder screws near the bottom.

1b. Heritage and Wrought Iron Front Removal

Remove the two screws in the slots located behind the inner arch. (Fig. 50) Tilt forward slightly and lift from the 2 shoulder screws near the bottom front. **Note: Fronts are heavy so when the second screw is removed the front will want to fall forward.**

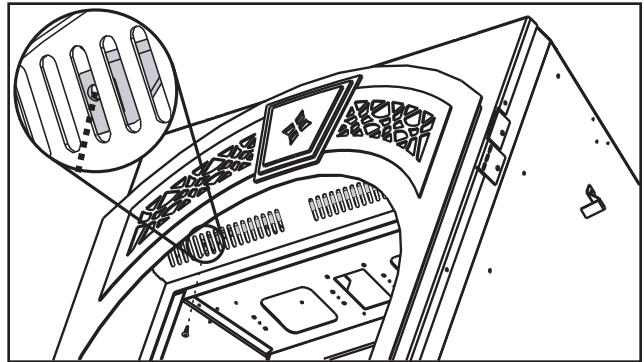

FIGURE 50

2. Control Panel Removal

Lift the panel from the slots. This will allow access and removal of the remote receiver and spark module.

If valve replacement is necessary following steps 1 and 2 above then proceed with the following ...

3. Door Removal

The glass door is secured at the top front edge of the fireplace. Pull the latch forward then lift hook out from slot in the door. Pivot door forward then lift out from retainer along the bottom edge of the firebox.

4. Burner Removal

The phasoramic burner must be removed next. Remove the 2 screws holding the air deflector (Fig. 51). Then remove the 3 screws holding the burner - 2 at the back and 1 at the front (Fig. 52).

Lift the burner out from the firebox.

5. Next, remove the 5 screws that secure the burner base. Once the gas has been disconnected, the burner train assembly will lift out.



FIGURE 51



FIGURE 52

OPERATION / MAINTENANCE

TIME OUT

If the appliance is turned on and the Receiver does not receive any command for 3 hours, it automatically turns the appliance and the Remote Control off.

FIREPLACE OPERATION

To operate this fireplace using the remote, the pilot must be running and the gas valve turned to the "ON" position. Ensure that the receiver has power and the backup switch is in the auto position.



FIGURE 53

1. Install the batteries (AAA) into the remote control transmitter. The "HOUSE" icon with room temperature will be displayed.

2. Press the ON/OFF button on the remote. Icons will appear at the same time and acoustic signal is generated if not, move the transmitter closer to the receiver and repeat. If a signal is still not heard, it will be necessary to execute the address setting procedure.

Note: There maybe a few seconds delay before the receiver responds. Especially when using the wrought iron faceplate.

3. Fahrenheit - Celsius temperature indicator

It is possible to set the Remote Control transmitter to display the temperatures in either Fahrenheit or Celsius. Use the UP or DOWN button on the transmitter until the cursor (small triangle) is left of the clock icon.

4. From time 0:00 press the LEFT key ten times. The display will show the transmitter address. Use the RIGHT button to toggle from °F to °C and vice versa. The display will show the selected unit of measue. Press the LEFT button to exit this function.

HAND HELD REMOTE OPERATIONS

1. ON / OFF

To turn the fireplace on press the ON / OFF button, the fireplace will always light at maximum flame setting. Press the ON / OFF button again to turn the fireplace off.

2. FLAME HEIGHT

This function allows remote control of the flame height. Check that the Remote Control is on, otherwise, turn on the Remote Control and wait 5 seconds. Select the manual flame height until the cursor (small triangle) is to the left of the big flame. (Figure 54) Use the RIGHT or LEFT button to set the

desired flame height. Six flame levels are included, from 1 (minimum) to 6 (maximum). An acoustic signal from the Receiver confirms the reception of the command.

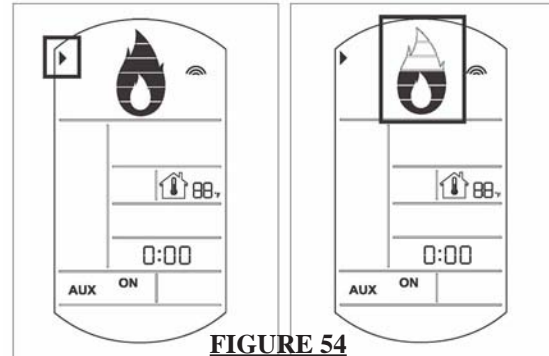

FIGURE 54

3. AUTOMATIC CHANGE OF FLAME HEIGHT

The system is provided with three automatic sequences to change continuously the flame height. Thirty steps compose each sequence with an interval between one step and the other of 5 seconds, for a total duration of 2.5 minutes. At the end the sequence repeats continually until the sequence function is changed to an alternate pattern or turned to off.

The Remote Control can select one of the predefined sequences. Use the UP or Down button until the cursor (small triangle) is to the left of the two small flames. (Figure 55)

Use the left or right button to select sequence 1, 2 or 3. When using the sequence function the room thermostat is active.

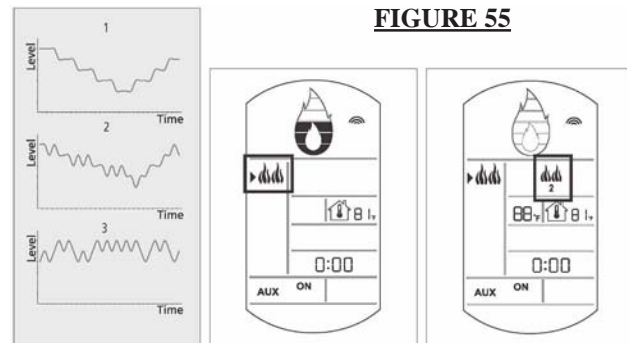

FIGURE 55

4. ROOM THERMOSTAT

The Remote Control can operate as a room thermostat.

To activate this function use the UP and DOWN key until the cursor (small triangle) is left of the thermometer icon. Then use the right of left button to set the desired room temperature. (Figure 56)

This control system will cycle automatically the appliance on or off to maintain the selected temperature.

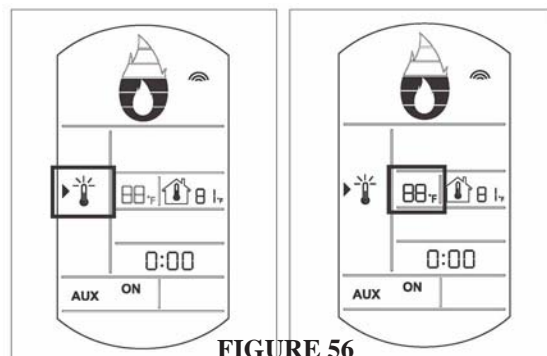

FIGURE 56

5. FAN SPEED SETTING

This function controls the speed of the hot air circulating fan. To change the fan speed, use the UP and Down button until the cursor (small triangle) is left of the fan icon. Set to one of 4 levels included or turned off (level 4 means full speed)

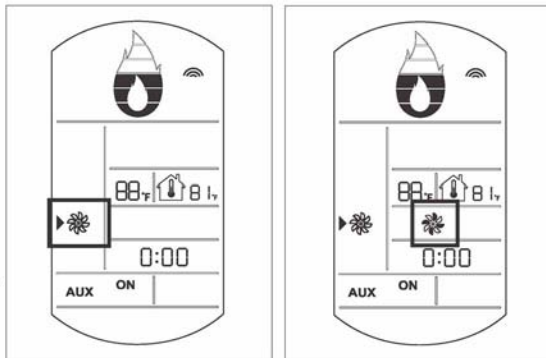

FIGURE 57

6. TIMER SETTING

The Remote Control has a sleep function. With this function it is possible to set a sleep time. After this time has elapsed the appliance is automatically switched off. To activate the function use the UP and DOWN button until the cursor (small triangle) is to the left of the clock icon.

Then use the right or left button to set the desired sleep time. It is possible to set a maximum time of 90 minutes with 15 minutes steps. After the desired time has been set press the UP or DOWN key to start the timer. (Figure 58)

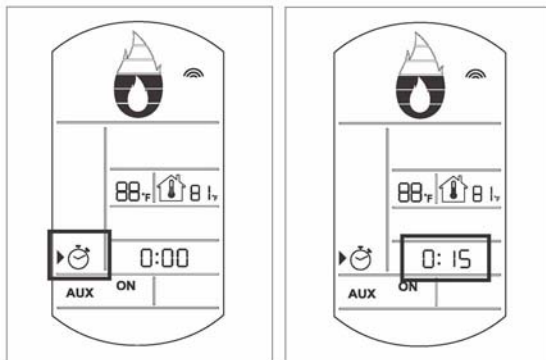

FIGURE 58

7. AUXILIARY OUTPUT

The auxiliary function allows switching of the accent light accessory on or off.

To control the accent light use the UP and DOWN button until the cursor (small triangle) is to the left of the AUX word. The right button turns the light on and the left button turns it off. (Figure 59)

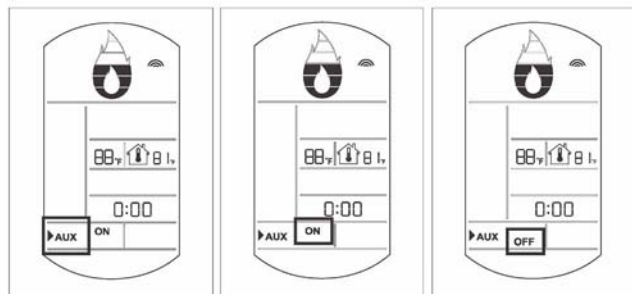

FIGURE 59

CHILD SAFETY LOCK-OUT

This function is to deactivate control button. The function is active when the lock icon is lit. To activate this function press the ON / OFF button and within one second the UP key

To reactivate the remote control buttons follow the same sequence, press ON / OFF key and within one second press the UP button.

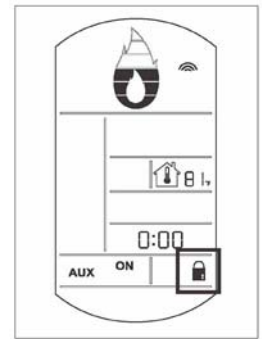

FIGURE 60

POWER FAILURE

During main power loss it is not possible to turn on the appliance with the Remote Control. It is possible to turn the appliance on manually using the Backup switch of the Receiver set to the MAN position. (Figure 53) The receiver is located in the control area (see steps 1 and 2 or page 19 - Once the main power has been restored the receiver must be returned to the auto position for remote control.

NOTE: On subsequent restoration of the main power and with the BACKUP switch in AUTO position, the Receiver leaves the appliance turned off even if the Remote Control is turned on. In this case, to switch on the appliance, press the ON / OFF button of the Remote Control twice.

LOW BATTERY DETECTION

The duration of the batteries depends on many factors: the quality of the batteries used, the number of ignitions of the appliance, the number of changes to the flame height etc.

When the transmitter batteries are low, an icon will be displayed on the LCD display to alert of a low battery condition before losing battery power at all. As soon as the depleted batteries are replaced, the transmitter will restart its normal operation.

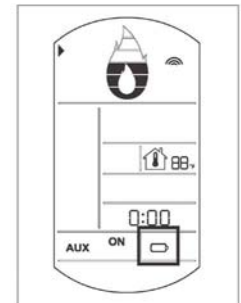

FIGURE 61

ADDRESS SETTING PROCEDURE

Use the UP and DOWN key on the transmitter until the cursor (small triangle) is left of the clock icon. From time 0:00 press the LEFT key ten times. The display will show then the transmitter address. Press the LEFT key to exit this function.

The transmitter address is required to be equal to the Receiver. (Figure 62) Select, through setting of the dip switches, the address of the receiver. (Figure 64) Switch #8 must always be in the ON position (down). It is also possible to start a receiver address search sequence through the Transmitter. To enter this function use the DOWN or UP keys until the cursor (small triangle) is left of the clock icon. From time 0:00 press the LEFT key ten times. The display will then show the present transmitter address. To alter the address of the Transmitter press the UP key to increase and DOWN to decrease it.

A "beep" from the Receiver will confirm the same address as the Transmitter. Press LEFT key to exit this function.

Note: The address of the Receiver is acquired only at its power on. Changing the address while the Receiver is powered will not have any effect. To change the address of the Receiver, disconnect the power cable from the Receiver, change the address and reconnect the power cable to the Receiver.

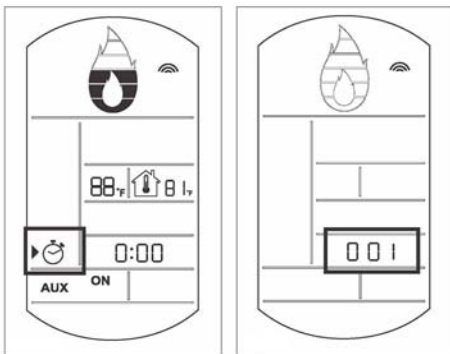

FIGURE 62

FAHRENHEIT - Celsius Temperature Indication

It is possible to set the Remote Control to display the temperatures in either Fahrenheit or Celsius. Use the UP or DOWN key on the Transmitter until the cursor (small triangle) is left of the click icon. From time 0:00 press the LEFT key ten times. The display will show the transmitter address. Use the RIGHT key to toggle from °F to °C and vice versa. The display will show the selected unit of measure. Press the LEFT key to exit this function. (Figure 63)

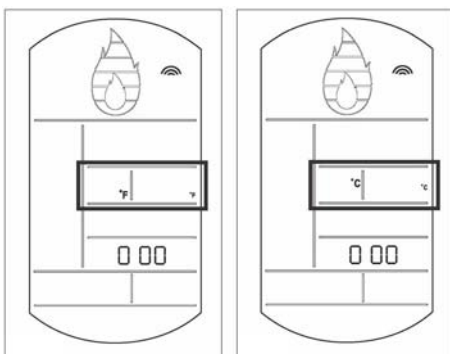

FIGURE 63

DIP SWITCH NUMBER (0 = ON / 1 = OFF)

ADDRESS	1	2	3	4	5	6	7	8
0	1	0	0	0	0	0	0	0
1	1	0	0	0	0	0	0	0
2	0	1	0	0	0	0	0	0
3	1	1	0	0	0	0	0	0
4	0	0	1	0	0	0	0	0
5	1	0	1	0	0	0	0	0
6	0	1	1	0	0	0	0	0
7	1	1	1	0	0	0	0	0
8	0	0	0	1	0	0	0	0
9	1	0	0	1	0	0	0	0
10	0	1	0	1	0	0	0	0
11	1	1	0	1	0	0	0	0
12	0	0	1	1	0	0	0	0
13	1	0	1	1	0	0	0	0
14	0	1	1	1	0	0	0	0
15	1	1	1	1	0	0	0	0
16	0	0	0	0	1	0	0	0
17	1	0	0	0	1	0	0	0
18	0	1	0	0	1	0	0	0
19	1	1	0	0	1	0	0	0
20	0	0	1	0	1	0	0	0
21	1	0	1	0	1	0	0	0
22	0	1	1	0	1	0	0	0
23	1	1	1	0	1	0	0	0
24	0	0	0	1	1	0	0	0
25	1	0	0	1	1	0	0	0
26	0	1	0	1	1	0	0	0
27	1	1	0	1	1	0	0	0
28	0	0	1	1	1	0	0	0
29	1	0	1	1	1	0	0	0
30	0	1	1	1	1	0	0	0
31	1	1	1	1	1	0	0	0
32	0	0	0	0	0	1	0	0
33	1	0	0	0	0	1	0	0
34	0	1	0	0	0	1	0	0
35	1	1	0	0	0	1	0	0
36	0	0	1	0	0	1	0	0
37	1	0	1	0	0	1	0	0
38	0	1	1	0	0	1	0	0
39	1	1	1	0	0	1	0	0
40	0	0	0	1	0	1	0	0
41	1	0	0	1	0	1	0	0
42	0	1	0	1	0	1	0	0
43	1	0	1	0	1	0	0	0
44	0	0	1	1	0	1	0	0
45	1	0	1	1	0	1	0	0
46	0	1	1	1	0	1	0	0
47	1	1	1	1	0	1	0	0
48	0	0	0	0	1	1	0	0
49	1	0	0	0	1	1	0	0
50	0	1	0	0	1	1	0	0
51	1	1	0	0	1	1	0	0
52	0	0	1	0	1	1	0	0
53	1	0	1	0	1	1	0	0
54	0	1	1	0	1	1	0	0
55	1	1	1	0	1	1	0	0
56	0	0	0	1	1	1	0	0
57	1	0	0	1	1	1	0	0
58	0	1	0	1	1	1	0	0
59	1	1	0	1	1	1	0	0
60	0	0	1	1	1	1	0	0
61	1	0	1	1	1	1	0	0
62	0	1	1	1	1	1	0	0
63	1	1	1	1	1	1	0	0
64	0	0	0	0	0	0	1	0
65	1	0	0	0	0	0	1	0
66	0	1	0	0	0	0	1	0
67	1	1	0	0	0	0	1	0
68	0	0	1	0	0	0	1	0
69	1	0	1	0	0	0	1	0
70	0	1	1	0	0	0	1	0
71	1	1	1	0	0	0	1	0
72	0	0	0	1	0	0	1	0
73	1	0	0	1	0	0	1	0
74	0	1	0	1	0	0	1	0
75	1	1	0	1	0	0	1	0
76	0	0	1	1	0	0	1	0
77	1	0	1	1	0	0	1	0
78	0	1	1	1	0	0	1	0
79	1	1	1	1	0	0	1	0
80	0	0	0	0	1	0	1	0
81	1	0	0	0	1	0	1	0
82	0	1	0	0	1	0	1	0
83	1	1	0	0	1	0	1	0
84	0	0	1	0	1	0	1	0
85	1	0	1	0	1	0	1	0
86	0	1	1	0	1	0	1	0
87	1	1	1	0	1	0	1	0
88	0	0	0	0	1	0	1	0
89	1	0	0	1	1	0	1	0
90	0	1	0	1	1	0	1	0
91	1	1	0	1	1	0	1	0
92	0	0	1	1	1	0	1	0
93	1	0	1	1	1	0	1	0
94	0	1	1	1	1	0	1	0
95	1	1	1	1	0	1	0	0
96	0	0	0	0	0	1	1	0
97	1	0	0	0	0	1	1	0
98	0	1	0	0	0	1	1	0
99	1	1	0	0	0	1	1	0
100	0	0	1	0	0	0	1	0
101	1	0	1	0	0	0	1	0
102	0	1	1	0	0	1	1	0
103	1	1	1	0	0	1	1	0
104	0	0	0	1	0	1	1	0
105	1	0	0	1	0	1	1	0
106	0	1	0	1	0	1	1	0
107	1	0	1	0	1	0	1	0
108	0	0	1	1	0	1	1	0
109	1	0	1	1	0	1	1	0
110	0	1	1	1	0	1	1	0
111	1	1	1	1	0	1	1	0
112	0	0	0	0	1	1	1	0
113	1	0	0	0	1	1	1	0
114	0	1	0	0	1	1	1	0
115	1	1	0	0	1	1	1	0
116	0	0	1	0	1	1	1	0
117	1	0	1	0	1	1	1	0
118	0	1	1	0	1	1	1	0
119	1	1	1	0	1	1	1	0
120	0	0	0	1	1	1	1	0
121	1	0	0	1	1	1	1	0
122	0	1	0	1	1	1	1	0
123	1	1	0	1	1	1	1	0
124	0	0	1	1	1	1	1	0
125	1	0	1	1	1	1	1	0
126	0	1	1	1	1	1	1	0
127	1	1	1	1	1	1	1	0

FIGURE 64

OPERATING INSTRUCTIONS

When lit for the first time, the fireplace will emit a slight odour for a few hours. This is a normal temporary condition caused by the curing of paints and lubricants used in the manufacturing process and will not occur again. Simply open a window to sufficiently ventilate the room.

After extended periods of non-operation such as following a vacation or a warm weather season, the fireplace may emit a

slight odour for a few hours. This is caused by dust particles in the heat exchanger burning off. Open a window to sufficiently ventilate the room.

Purge all gas lines with the glass door of the fireplace open. Assure that a continuous gas flow is at the burner before closing the door.

FOR YOUR SAFETY READ BEFORE

- A. This fireplace is equipped with a pilot which must be lit by hand while following these instructions exactly.
- B. Before operating smell all around the fireplace area for gas and next to the floor because some gas is heavier than air and will settle on the floor.
- C. Use only your hand to turn the gas control knob / manual shut-off knob. never use tools. if the knob will not turn by hand, do not try to repair it. call a qualified service technician. force or attempted repair may result in a fire or explosion.
- D. Do not use this fireplace if any part has been under water. immediately call a qualified service technician to inspect the fireplace and replace any part of the control system and any gas control which has been under water.

WHAT TO DO IF YOU SMELL GAS

- Do not touch any electric switch.
- Do not use any phone in your building.
- If you cannot reach your gas supplier, call the fire department.
- Turn off all gas to the fireplace.
- Do not try to light any appliance.
- Immediately call your gas supplier from a neighbor's phone. Follow the gas supplier's instructions.

FIGURE 65



LIGHTING INSTRUCTIONS

Warning: if you do not follow these instructions exactly, a fire or explosion may result causing property damage, personal injury or loss of life. Initial lighting of the pilot and main burners must be done with the glass door off. Do not connect valve or wall switch to electricity. See installation instructions.

When lighting and re-lighting, the gas knob cannot be turned from pilot to off unless the knob is depressed slightly.

1. STOP! read the safety information on the operating label.
2. Turn off all electric power to the fireplace.
3. Turn the gas knob clockwise to off.
4. Wait 5 minutes to clear out any gas. If you smell gas, including near the floor, STOP! Follow "B" on the operating label. If you don't smell gas, go to the next step.
5. If the fireplace is equipped with a flame adjustment valve, turn clockwise to off.
6. Find pilot located in front of the back log on the right side.

7. Turn gas knob counter-clockwise to pilot.
8. This unit is equipped with an auto-spark. Depress and hold gas knob. Keep knob fully depressed for one minute, then release. If pilot does not continue to burn repeat steps 3 through 7.
9. With pilot lit, turn gas knob counter-clockwise to on.
10. If equipped with flame adjustment valve, push and turn knob to high.
11. If equipped with remote on-off switch, main burner may not come on when you turn the valve to on or high. Remote switch must be in the on position to ignite burner.
12. Turn on all electric power to the fireplace.

FIGURE 66

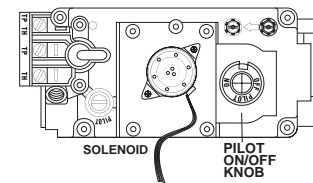

TO TURN OFF GAS

1. Turn off all electric power to the fireplace if service is to be performed.
2. For a complete shut-down procedure: push in gas control knob slightly and turn clockwise to off. Do not force.
3. For a temporary shut-down procedure: set thermostat to lowest setting or remote switch to off. Press and turn the gas knob clockwise to pilot.

MAINTENANCE

TURN OFF THE GAS AND ELECTRICAL POWER BEFORE SERVICING THE FIREPLACE.

CAUTION: Label all wires prior to disconnection when servicing controls. Wiring errors can cause improper and dangerous operation. Verify proper operation after servicing. This fireplace and its venting system should be inspected before use and at least annually by a qualified service person. The fireplace area must be kept clear and free of combustible materials, gasoline or other flammable vapours and liquids. The flow of combustion and ventilation air must not be obstructed.

1. In order to properly clean the burner and pilot assembly, remove the logs to expose both assemblies.
2. Keep the control compartment, logs, burner, air shutter opening and the area surrounding the logs clean by vacuuming or brushing, *at least once a year*.

3. Check to see that all burner ports are burning. Clean out any of the ports which may not be burning or are not burning properly.
4. Check to see that the pilot flame is large enough to engulf the thermocouple and thermopile and reaches toward the burner with the third jet.
5. Replace the cleaned logs.
6. Check to see that the main burner ignites completely on all openings when the gas knob for the burner is turned on. A 5 to 10 second total light-up period is satisfactory. If ignition takes longer, consult your Napoleon dealer / distributor.
7. Check that the gasketing on the sides, top and bottom of the door is not broken or missing. Replace if necessary.

ADJUSTMENTS

PILOT BURNER ADJUSTMENT

Adjust the pilot screw to provide properly sized flame. Turn in a clockwise direction to reduce the gas flow.

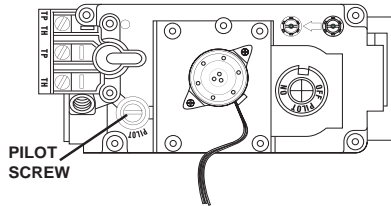

FIGURE 67

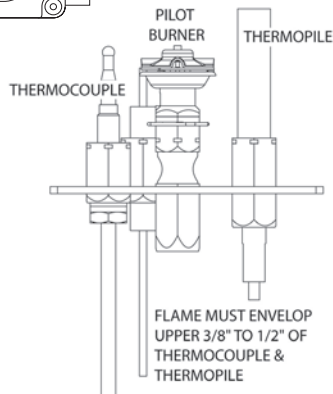

FIGURE 68

VENTURI ADJUSTMENT

Air Shutter Openings	
LP	1/2"
NG	1/16"

Closing the air shutter will cause a more yellow flame, but can lead to carboning. Opening the air shutter will cause a more blue flame, but can cause flame lifting from the burner ports. The flame may not appear yellow immediately; allow 15 to 30 minutes for the final flame colour to be established.

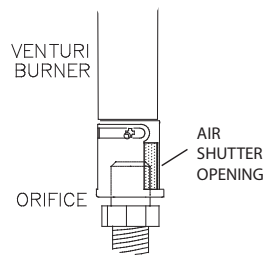

FIGURE 69

REPLACEMENTS

Contact your dealer for questions concerning prices and availability of replacement parts. Normally all parts can be ordered through your Napoleon dealer or distributor. When ordering replacement parts always give the following information:

1. MODEL & SERIAL NUMBER OF FIREPLACE
2. INSTALLATION DATE OF FIREPLACE
3. PART NUMBER
4. DESCRIPTION OF PART
5. FINISH

FOR WARRANTY REPLACEMENT PARTS, A PHOTOCOPY OF THE ORIGINAL INVOICE WILL BE REQUIRED TO HONOUR THE CLAIM.

*** IDENTIFIES ITEMS WHICH ARE NOT ILLUSTRATED. FOR FURTHER INFORMATION, CONTACT YOUR NAPOLEON DEALER.**

REPLACEMENT PARTS

#	PART NO.	DESCRIPTION
1	W135-0267	#1 - REAR LOG
2	W135-0268	#2 - MIDDLE LOG
3	W135-0269	#3 - RIGHT LOG
4	W135-0270	#4 - LEFT LOG
5	W135-0273	#5 - LEFT STICK
6	W135-0274	#6 - RIGHT STICK
7	GL-654	LOG SET ASSEMBLY
8*	W390-0002	DOOR LATCH (EA)
9	W725-0044	NATURAL GAS VALVE - MODULATING
9	W725-0045	PROPANE GAS VALVE - MODULATING
10	W455-0017	NATURAL GAS ORIFICE #42
10	W455-0003	PROPANE GAS ORIFICE #54
11	W680-0005	THERMOCOUPLE **
12	W240-0005	ELECTRODE c/w LEAD
13	W680-0004	THERMOPILE
14	W010- 1194	NATURAL GAS PILOT ASSEMBLY
14	W010- 1201	PROPANE GAS PILOT ASSEMBLY
15	W455-0070	NG PILOT INJECTOR
15	W455-0068	LP PILOT INJECTOR
16*	W385-0245	NAPOLEON LOGO
17*	W562-0008	DOOR GASKET (100 INCHES)
18	W100-0087	BURNER
19	GD 552	BLOWER
20	W660-0041	SPARK SWITCH
21	W660-0046	REMOTE TRANSMITTER
22	W660-0045	REMOTE RECEIVER
23	W190-0017	DC SPARK UNIT CONTROL
24	W300-0067	ACCENT LIGHT GLASS
25	W387-0006	ACCENT LAMP
26	W750-0107	ACCENT LIGHT WIRE
27	W290-0080	ACCENT LENSE GASKET
28*	W361-0027	INSULATION SLEEVE
29*	W475-0401	PANEL, REAR FIBRE
30*	W475-0402	PANEL, RIGHT FIBRE
31*	W475-0403	PANEL, LEFT FIBRE
32	W225-0171	DOOR
33*	W300-0082	GLASS
34	W500-0205	RESTRICTOR
35	W585-0198	FIRESTOP SPACER SHIELD
36	W500-0292	FIRESTOP SPACER

FLEXIBLE VENT KITS

GD220 (5 FT)

40*	W010-0397	4" FLEXIBLE ALUMINIUM LINER - (5 FT) C/W SPACERS
40*	W410-0017	7" FLEXIBLE ALUMINIUM LINER - (5 FT)

GD330 (10 FT)

41*	W010-0300	4" FLEXIBLE ALUMINIUM LINER - (10 FT) C/W SPACERS
41*	W410-0018	7" FLEXIBLE ALUMINIUM LINER - (10 FT)
42*	W010-0370	WALL SUPPORT ASSEMBLY

TERMINAL KITS

43	PERISCOPE	- GD201
44	WALL TERMINAL KIT	- GD222R

ROOF TERMINAL KITS

45*	1/12 TO 7/12 PITCH	- GD110
46*	8/12 TO 12/12 PITCH	- GD111
47*	FLAT ROOF	- GD112
48*	W490-0073	4/7 INNER/OUTER SLEEVE
49	W670-0006	4/7 TERMINAL
50	W170-0086	STORM COLLAR
51	W010-0453	ROOF SUPPORT
52	W263-0065 / W263-0066 / W263-0067	ROOF FLASHING

ACCESSORIES

53*	W573-0007	HI-TEMP SEALANT
54*	GD501	HEAT GUARD
55	GA-566	HOT AIR DISTRIBUTION KIT
56	GA-72	HOT AIR EXHAUST KIT
57	GA-70	EXTENSION KIT, 5FT FLEX VENT
58*	W010-0370	WALL SUPPORT ASSEMBLY
59*	W175-0001	4" COUPLER
60*	W175-0013	7" COUPLER
61*	W175-0239	CONVERSION KIT - NG TO LP
62*	W175-0240	CONVERSION KIT - LP TO NG
63	GD811-KT	HERRINGBONE/SANDSTONE BRICK KIT
64	W135-0148	ANDIRON
65*	GD812-KT	REFRACTORY PANEL KIT
66	RFK82	RECTANGLE FACING KIT
67	AFK82	ARCHED FACING KIT
68*	RFK82WI	WROUGHT IRON FACING KIT
69	W135-0271	ANDRION (OBELISK)

**** WARNING:** This is a fast acting thermocouple. It is an integral safety component. Replace only with a fast acting thermocouple supplied by Wolf Steel Ltd.

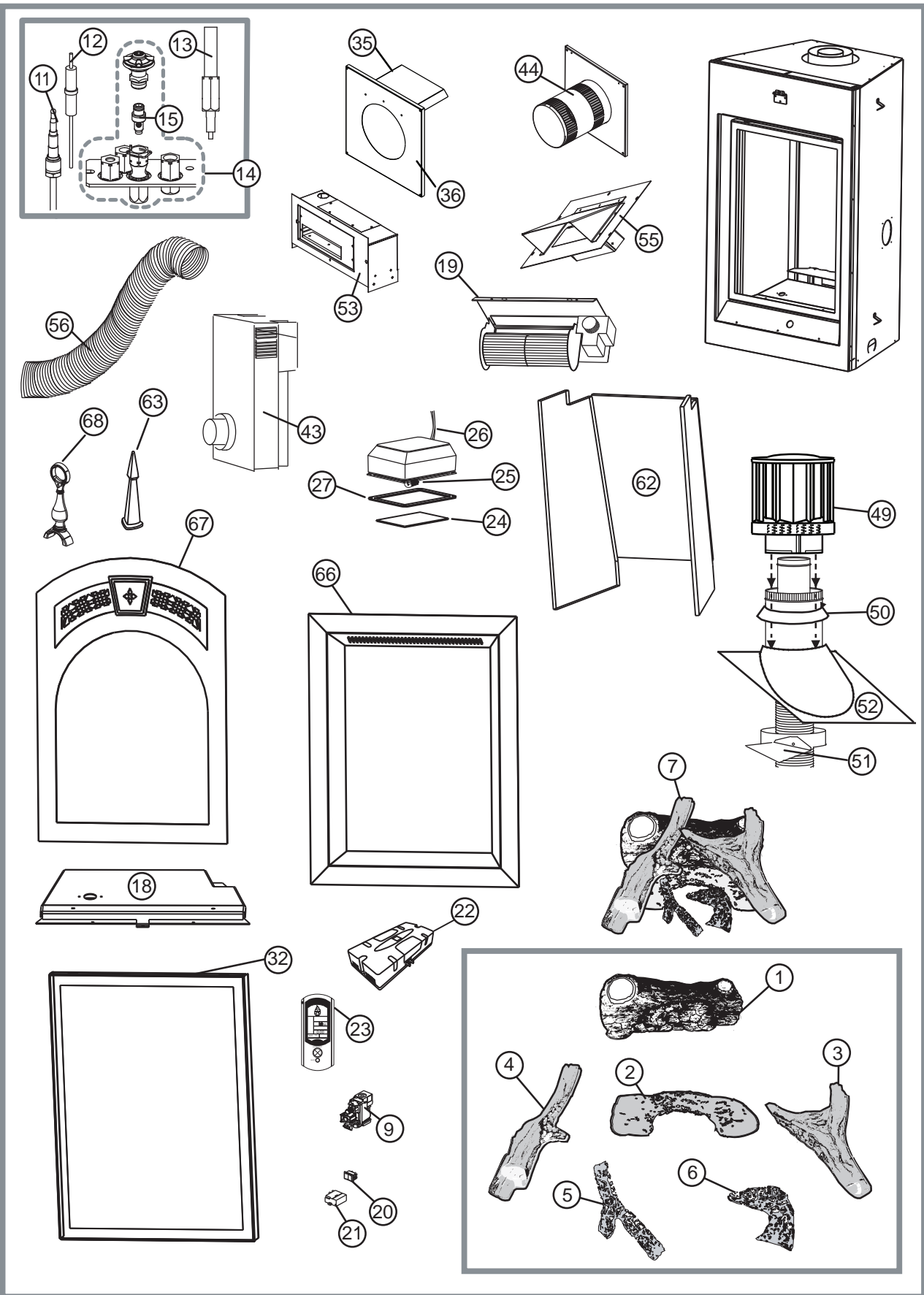

TROUBLE SHOOTING GUIDE

BEFORE ATTEMPTING TO TROUBLESHOOT, PURGE YOUR UNIT AND INITIALLY LIGHT THE PILOT AND THE MAIN BURNER WITH THE GLASS DOOR OPEN.

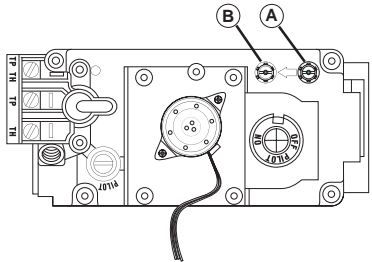
SYMPTOM	PROBLEM	TEST SOLUTION
Main burner flame is a blue, lazy, transparent flame.	Blockage in vent.	- remove blockage. In really cold conditions, ice buildup may occur on the terminal and should be removed as required.
	Incorrect installation.	- refer to Figure 13 to ensure correct location of storm collars.
Flames are consistently too large or too small. Carboning occurs.	Unit is over-fired or under-fired.	- check pressure readings: Inlet pressure can be checked by turning screw (A) counter-clockwise 2 or 3 turns and then placing pressure gauge tubing over the test point. Gauge should read 7" (minimum 4.5") water column for natural gas or 13" (11" minimum) water column for propane. Check that main burner is operating on "HI". Outlet pressure can be checked the same as above using screw (B). Gauge should read 3.5" water column for natural gas or 10" water column for propane. Check that main burner is operating on "HI". AFTER TAKING PRESSURE READINGS, BE SURE TO TURN SCREWS CLOCKWISE FIRMLY TO RESEAL. DO NOT OVERTORQUE. Leak test with a soap and water solution.
		
Carbon is being deposited on glass, logs or combustion chamber surfaces.	Air shutter has become blocked	- ensure air shutter opening is free of lint or other obstructions.
	Flame is impinging on the logs or combustion chamber.	- check that the logs are correctly positioned. - open air shutter to increase the primary air. - check the input rate: check the manifold pressure and orifice size as specified by the rating plate values. - check that the door gasketing is not broken or missing and that the seal is tight. - check that both 4" and 7" vent liners are free of holes and well sealed at all joints. - check that minimum rise per foot has been adhered to for any horizontal venting.
White / grey film forms.	Sulphur from fuel is being deposited on glass, logs or combustion chamber sur-	- clean the glass with a gas fireplace glass cleaner. DO NOT CLEAN GLASS WHEN HOT. If deposits are not cleaned off regularly, the glass may become permanently marked.
Exhaust fumes smelled in room, headaches.	Fireplace is spilling.	- check door seal and relief flap seal. - check for chimney blockage - check that the paint curing process is complete
Pilot goes out when the gas knob is released. The gas valve has an interlock device which will not allow the pilot burner to be lit until the thermocouple has cooled. Allow approximately 60 seconds for the thermocouple to cool.	System is not correctly purged.	- purge the gas line with the glass door open.
	Out of propane gas.	- fill the tank.
	Pilot flame is not large	- turn up the pilot flame.
	Pilot flame is not engulfing the thermocouple.	- gently twist the pilot head to improve the flame pattern around the thermocouple.
	Thermocouple shorting / faulty.	- loosen and tighten thermocouple. - clean thermocouple and valve connection. - replace thermocouple. - replace valve.
	Faulty valve.	- replace.

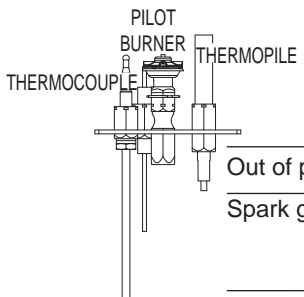
SYMPTOM	PROBLEM	TEST SOLUTION
Pilot burning; no gas to main burner; gas knob is on 'HI'; wall switch / thermostat is on.	Thermostat or switch is defective.	- connect a jumper wire across the wall switch terminals; if main burner lights, replace switch / thermostat.
	Wall switch wiring is defective.	- disconnect switch wires & connect a jumper wire across terminals 1 & 3; if the main burner lights, check the wires for defects and / or replace wires.
	Main burner orifice is faulty valve.	- remove stoppage in orifice. - replace.
Pilot goes out while standing; Main burner is in 'OFF' position.	Gas piping is undersized.	- turn on all gas appliances and see if pilot flame flutters, diminishes or extinguishes, especially when main burner ignites. Monitor appliance supply working pressure. - check if supply piping size is to code. Correct all undersized piping.
Pilot will not light. 	No spark at pilot burner	- check if pilot can be lit by a match - check that the wire is connected to the push button ignitor. - check if the push button ignitor needs tightening. - replace the wire if the wire insulation is broken or frayed. - replace the electrode if the ceramic insulator is cracked or broken. - replace the push button ignitor.
	Out of propane gas	- fill the tank.
	Spark gap is incorrect	- spark gap should be 0.150" to 0.175" (5/32" to 11/64" approx.) from the electrode tip and the pilot burner. To ensure proper electrode location, tighten securing nut (finger tight plus 1/4 turn).
	No gas at the pilot burner	- check that the manual valve is turned on. - check the pilot orifice for blockage. - replace the valve. - call the gas distributor.
Main burner goes out; pilot stays on.	Pilot flame is not large enough or not engulfing the thermopile	- turn up pilot flame. - replace pilot assembly.
	Thermopile shorting	- clean thermopile connection to the valve. Reconnect. - replace thermopile / valve.
	Remote wall switch wire is too long; too much resistance in the system.	- shorten wire to correct length or wire gauge.
	Faulty thermostat or switch.	- replace.
Main burner goes out; pilot goes out.	Refer to "MAIN BURNER GOES OUT; PILOT STAYS ON"	
	Vent is blocked	- check for vent blockage.
	Vent is re-circulating	- check joint seals and installation.
	4" flexible vent has become disconnected from fireplace.	- re-attach to fireplace.
Remote wall switch is in "OFF" position; main burner comes on when gas knob is turned to "ON" position.	Wall switch is mounted upside down	- reverse.
	Remote wall switch is grounding.	- replace.
	Remote wall switch wire is grounding.	- check for ground (short); repair ground or replace wire.
	Faulty valve.	- replace.

